

SONOACE X6 Service Manual

ENGLISH

Document No. CSD-SMEX6

Revision 00

Safety Requirements

Classifications:

- Type of protection against electrical shock: Class I
- Degree of protection against electrical shock (Patient connection): Type BF equipment
- Degree of protection against harmful ingress of water: Ordinary equipment
- Degree of safety of application in the presence of a flammable anesthetic material with air or with oxygen or nitrous oxide: Equipment not suitable for use in the presence of a flammable anesthetic mixture with air or with oxygen or nitrous oxide.
- Mode of operation: Continuous operation

Electromechanical safety standards met:

- IEC/EN 60601-1 Medical Electrical Equipment, Part 1 General Requirements for Safety.
- IEC/EN 60601-1-1 Safety requirements for medical electrical systems.
- IEC/EN 60601-1-2 Electromagnetic compatibility -Requirements and tests.
- IEC/EN 60601-2-37 Particular requirements for the safety of ultrasonic medical diagnostic and monitoring equipment.
- IEC 61157 Declaration of acoustic output parameters.
- ISO 10993-1 Biological evaluation of medical devices.
- UL 2601-1 Medical Electrical Equipment, Part 1 General Requirements for Safety.
- CSA 22.2, 601.1 Medical Electrical Equipment, Part 1 General Requirements for Safety.

Declarations;



This is CSA symbol for Canada and United States of America



This is manufacturer's declaration of product compliance with applicable EEC directive(s) and the European notified body.



This is manufacturer's declaration of product compliance with applicable EEC directive(s).

READ THIS FIRST

Before asking for the product to be repaired, read this service manual thoroughly, learn how to troubleshoot, and make sure you understand the precautions fully.

The repair of the system and the replacement of parts must be carried out by an authorized dealer or the customer care department of MEDISON Co., Ltd.

The company shall not be held liable for any injury and damage caused by not following this warning.

For safe use of this product, you should read 'Chapter 2. Safety' in this manual, prior to starting to using this system.

DANGER

Describes precautions necessary to prevent user hazards of great urgency. Ignoring a DANGER warning will risk life-threatening injury.

WARNING

Used to indicate the presence of a hazard that can cause serious personal injury, or substantial property damage.

CAUTION

Indicates the presence of a hazard that can cause equipment damage.

NOTE

A piece of information useful for installing, operating and maintaining a system. Not related to any hazard.

Contents

Chapter 1. General Information	1-1
1.1 Overview	1-1
1.2 Features and Advantages of SONOACE X6	1-2
1.3 Product Configuration	1-3
1.3.1 Console	1-3
1.3.2 LCD Monitor	1-5
1.3.3 Control Panel	1-6
1.3.4 Probe	1-7
1.4 Specifications	1-8
Chapter 2. Safety	2-1
2.1 Overview	2-1
2.2 Safety – Related Information	2-2
2.2.1 Safety Symbols	2-2
2.2.2 Label	2-4
2.3 Electrical Safety	2-6
2.3.1 Prevention Electric Shock	2-6
2.3.2 ECG – Related Information	2-7
2.3.3 ESD	2-8
2.3.4 EMI	2-8
2.3.5 EMC	2-9
2.4 Mechanical Safety	2-15
2.4.1 Moving the Equipment	2-15
2.4.2 Safety Note	2-16
2.5 Biological Safety	2-17
2.5.1 ALARA Principle	2-17
2.6 Environmental Protection	2-29

Contents

Chapter 3. Installing the Product	3-1
3.1 Overview	3-1
3.2 Transportation	3-3
3.2.1 Precautions for Transportation	3-3
3.2.2 Temperature and Humidity	3-3
3.2.3 Transportation of the Product	3-4
3.3 Unpacking	3-5
3.3.1 Unpacking the Box	3-5
3.3.2 Checking Package Contents	3-6
3.4 Precautions for Installation	3-7
3.4.1 Precautions	3-7
3.4.2 Installation Location	3-8
3.5 Installation Procedure	3-9
3.5.1 Installation Safety	3-9
3.5.2 Connecting the Power Cord	3-10
3.5.3 Connecting the Network Cable	3-11
3.5.4 Connecting the Foot switch	3-11
3.5.5 Connecting the Probe	3-12
3.6 Starting the Product	3-13
3.7 Shutting down the Product	3-15
3.7.1 Power Switch	3-15
3.7.2 Cut-off Switch	3-15
3.8 Connecting the Peripherals	3-16
3.8.1 BW Printer	3-16
3.8.2 Color Printer	3-17
3.8.3 Line Printer	3-18
3.8.4 VCR	3-18
3.8.5 USB Storage Device	3-19
3.9 System Setting	3-20
3.9.1 General System Setup	3-20
3.9.2 Display Setup	3-22
3.9.3 Misc	3-24
3.9.4 Peripherals Setup	3-25
3.9.5 Information	3-26
3.9.6 DICOM Setup (Option)	3-27
3.9.7 Option Setup	3-34

Contents

Chapter 4. Checking the Product	4-1
4.1 Overview	4-1
4.2 Starting the Product.....	4-2
4.3 Monitor	4-6
4.3.1 Monitor Display	4-4
4.4 Control Panel	4-6
4.4.1 Power On/Off	4-6
4.4.2 Starting and Finishing Exam.....	4-6
4.4.3 Selecting Diagnosis mode and Gain Control.....	4-7
4.4.4 Image Adjustment.....	4-9
4.4.5 TGC	4-10
4.4.6 Measurement and Annotation.....	4-10
4.4.7 Trackball and its related control.....	4-11
4.4.8 SONOVIEW and Report.....	4-12
4.4.9 Save and Print.....	4-12
4.4.10 Alphanumeric keyboard.....	4-13
4.4.11 Flexible Soft Buttons.....	4-13
4.4.12 Function Buttons.....	4-14
4.5 Checking the Performance.....	4-15
4.5.1 Basic Check	4-15
4.5.2 Detail Check	4-16

Contents

Chapter 5. Product Structure	5-1
5.1 Overview	5-1
5.2 System Block Diagram	5-3
5.3 Basic Structure of SONOACE X6	5-4
5.3.1 Overview	5-4
5.3.2 Ultrasound System Part	5-5
5.3.3 User Interface Part	5-5
5.3.4 Power Part	5-5
5.4 PSA	5-6
5.5 Front End Board	5-9
5.6 CW Board	5-13
5.7 Back End Board	5-15
5.8 Rear Board	5-22
5.9 Control Panel	5-23
5.10 Power Supply	5-24
Chapter 6. Basic Maintenance	6-1
6.1 Overview	6-1
6.2 System Information	6-2
6.3 Entering Admin Mode	6-3
6.4 Upgrade	6-6
6.4.1 Software Upgrade	6-6
6.4.2 Hardware Upgrade	6-9
6.5 Backup & Restore	6-10
6.5.1 Backup User Setting	6-10
6.5.2 Restore User Setting	6-11
6.6 Adding and Deleting Options	6-13
6.6.1 Option type	6-13
6.6.2 Registering Options	6-13
6.6.3 Deleting Options	6-14
6.7 Control Panel Test	6-15

Contents

Chapter 7.	Troubleshooting	7-1
7.1	Overview	7-1
7.2	Power	7-2
7.2.1	Power Failure	7-2
7.2.2	Power cannot be turned off	7-2
7.2.3	Power is automatically turned off	7-3
7.3	Monitor	7-4
7.3.1	Blank Screen	7-4
7.3.2	Screen Color is Abnormal	7-4
7.4	Error Messages	7-5
7.4.1	System hangs after an error during booting	7-5
7.4.2	System works even if error occurred	7-5
7.4.3	Error code	7-5
7.5	Image	7-6
7.5.1	No BW Image Echo	7-6
7.5.2	No BW Mode Image Format	7-6
7.5.3	Noise Link Rain over the BW Mode Image (Noise)	7-6
7.5.4	PW Doppler Mode Trouble	7-7
7.5.5	CW Doppler Mode Trouble	7-7
7.5.6	Color Doppler Mode Trouble	7-7
7.5.7	Motion Mode Trouble	7-7

Contents

Chapter 8. Disassembly and Reassembly	8-1
8.1 Overview	8-1
8.2 Disassembly and Reassembly of the External Case	8-4
8.2.1 Preparations	8-4
8.2.2 Cover Front Lower	8-4
8.2.3 Cover Top Plate	8-5
8.2.4 Cover Rear Lower	8-6
8.3 Disassembly and Reassembly of the LCD Monitor	8-7
8.3.1 Preparations	8-7
8.3.2 LCD Monitor	8-7
8.3.3 LCD Monitor Arm	8-8
8.4 Disassembly and Reassembly of the Ultrasound System PCB Part	8-9
8.4.1 Preparations	8-9
8.4.2 PSA ASSY	8-9
8.4.3 CW Board, FE Board, BE Board	8-10
8.4.4 DC to DC Power Module	8-11
8.5 Disassembly and Reassembly of the HDD & DVD	8-12
8.5.1 Preparations	8-12
8.5.2 HDD & DVD	8-12
8.6 Disassembly and Reassembly of the Rear Panel	8-13
8.6.1 Preparations	8-13
8.6.2 Rear Right Board & Rear Left Board	8-13
8.6.3 Back Fan	8-14
8.7 Disassembly and Reassembly of the Power Supply	8-16
8.7.1 Preparations	8-16
8.7.2 AC to DC Power Module	8-16
8.7.3 DC to DC Power Module	8-16
8.8 Disassembly and Reassembly of the Control Panel	8-17
8.8.1 Preparations	8-17
8.8.2 Control Panel	8-17
8.8.3 Key Matrix Board	8-18
8.8.4 Track Ball	8-19
8.8.5 Alpha Numeric Keyboard	8-20
8.8.6 Speaker	8-20

Content

Chapter 9. Probe	9-1
9.1 Overview	9-1
9.2 Probe List	9-2
9.3 Thermal Index (TI Table)	9-3
9.4 Ultrasound Transmission Gel	9-4
9.5 Sheaths	9-5
9.6 Probe Precautions	9-5
9.7 Cleaning and Disinfecting the Probe	9-8
Chapter 10. User Maintenance	10-1
10.1 Overview	10-1
10.2 System Maintenance	10-2
10.2.1 Installation Maintenance	10-2
10.2.2 Cleaning and Disinfections	10-3
10.2.3 Fuse Replacement	10-5
10.2.4 Cleaning the Air Filter	10-6
10.2.5 Accuracy Check	10-6
10.3 Administration of Information	10-7
10.3.1 User Setting Back-up	10-7
10.3.2 Patient Information Back-up	10-7
10.3.3 Software	10-7
Chapter 11. Service Part List	11-1
11.1 Overview	11-1
11.2 Cover	11-2
11.3 Ultrasound System Part	11-4
11.4 Rear Plan	11-5
11.5 Power Part	11-6
11.6 LCD Monitor	11-7
11.7 Control Panel	11-9
11.8 Probe	11-10

1 General Information

1.1 Overview

Chapter 1 contains the information necessary to plan the Troubleshooting of SONOACE X6

The SONOACE X6 is a high-resolution color ultrasound system with high penetration and a variety of measurement functions

Contents General Information

1.1	Overview	1-1
1.2	Features and Advantages of SONOACE X6	1-2
1.3	Product Configuration	1-3
1.3.1	Console	1-3
1.3.2	LCD Monitor	1-5
1.3.3	Control Panel	1-6
1.3.4	Probes	1-7
1.4	Specifications	1-8

1.2 Features and Advantages of SONOACE X6

- High-end Digital Beamforming : The SONOACE X6 utilizes the newly developed Digital Beam forming technology.
- A variety of applications : The SONOACE X6 is optimized for use in a variety of ultrasound departments, including general, abdomen, obstetrics, gynecology, vascular, extremity, pediatric, cardiac, breast, urology, and etc.
- Various diagnostic Modes : 2D Mode, M Mode, Color Doppler Mode, Power Doppler Mode, PW Spectral Doppler Mode, CW Spectral Doppler Mode(Optional), etc.
- 3D images can be obtained.
- Measurement and Report Functions : Besides the basic distance, area, circumference and volume measurement functions, the SONOACE X6 also provides application-specific measurement functions. The report function collates measurement data.
- Review of Scanned Images : The SONOACE X6 displays Cine images of 512 frames and loop images of 4096 lines.
- SonoView™ : This is a total ultrasound image management system, which allows a user to archive, view and exchange documents.
- Digital Imaging and Communications in Medicine (DICOM) Function : This is used to archive, transmit and print DICOM images through a network.
- Peripheral/Accessory Connection : A variety of peripheral devices including VCRs and printers can be easily connected to the SONOACE X6.

1.3 Product Configuration

This Product consists of the monitor, the control panel, the console and the probes.

1.3.1 Console

The console consists of two parts – the inner unit and the outer unit.

The interior of the console mainly contains devices that produce ultrasound images. On the exterior of the console is composed of various connectors, probe holders, storage compartments, handles, wheels, etc.



[Figure 1-1] Console of SONOACE X6



[Figure 1-2] Rear and side of SONOACE X6

1.3.2 LCD Monitor

The LCD monitor of this system is a color VGA monitor, which displays ultrasound images and additional information. Use the monitor arm to adjust the height or position of the monitor.



[Figure 1-3] LCD Arm

1.3.3 Control Panel

The control panel can be used for controlling the system. It consists of the following four sections:

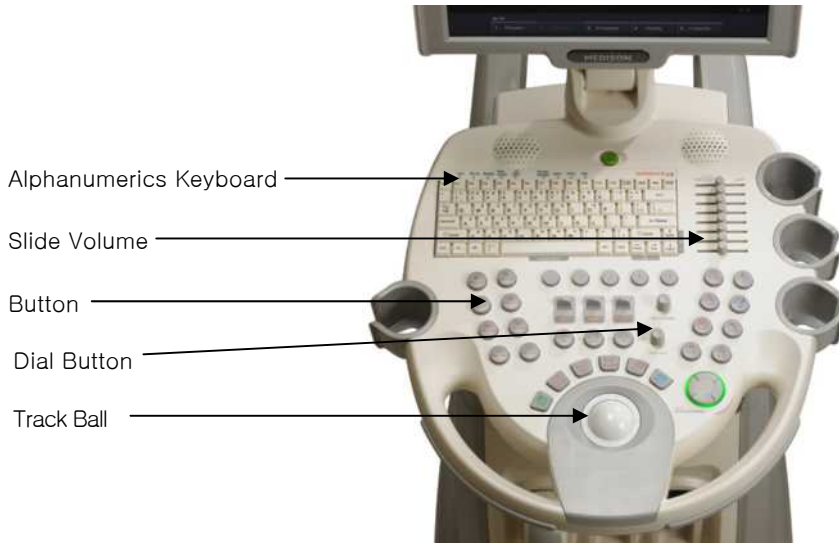

[Figure 1-4] Control Panel

1.3.4 Probe

Probes are devices that generate ultrasound waves and process reflected wave data for the purpose of image formation.

NOTE For more information, refer to `Chapter 9 Probes`.

1.4 Specifications

Physical Dimensions	Height: 1378mm (with monitor) Width: 483mm Depth: 691mm Weight: More than 60.75kg
Monitor	15 inch LCD monitor
Electrical Parameters	100–120V/200–240VAC, 8/5A, 50/60Hz
Pressure Limits	Operating: 700hPa to 1060hPa Storage: 700hPa to 1060hPa
Humidity Limits	Operating: 30% to 75% Storage & Shipping: 20% to 90%
Temperature Limits	Operating: 10°C ~ 35°C Storage & Shipping: -25°C ~ 60°C
Imaging modes	2D imaging mode Dual 2D imaging mode M imaging mode 2D/M imaging mode Color Doppler Imaging (CDI) mode Power Doppler Imaging (PDI) mode Pulse Wave (PW) Spectral Doppler imaging mode Continuous Wave (CW) Spectral Doppler imaging mode 3D imaging mode (Freehand) Simultaneous mode
Focusing	Transmit focusing, maximum of eight points (four points simultaneously selectable) Digital dynamic receive focusing (continuous)
Application	General, Gynecology, Abdomen, OB, Renal, Urology, Vascular, Small Part, Fetal Heart, Breast, Musculoskeletal, Pediatric, Cardiac, TCD, Neonatal

Measurement Packages	Trackball operation of multiple cursors 2D: Linear measurements and area measurements using elliptical approximation or trace M-mode: Continuous readout of distance, time, and slope rate Doppler: Velocity and trace
Image Storage	Maximum 512 frames for CINE memory Maximum 4096 Lines for LOOP memory Image filing system
Gray Scale	256 (8 bits)
Signal processing (Pre-processing)	TGC control Mode-independent gain control Acoustic power control (adjustable) Dynamic aperture Dynamic apodization Dynamic range control (adjustable) Image view area control M-mode sweep speed control HD zoom Frame average Gamma-scale windowing Image orientation (left/right and up/down) White on black/black on white
Probes	Curved Linear Array C3-7EP C4-9ED Linear Array HL5-12ED L5-12/50EP Endocavity Curved Linear Array NER4-9ES NEV4-9ES Phased Array P2-4AH CW CW2.0 CW4.0

Probe connections	<p>Three probe connectors</p> <p>Four probe connectors for option</p> <p>※ Including one CW probe connector.</p>
Rear Panel Input / Output Connections	<p>VHS and S-VHS VCR left and right audio</p> <p>ECG</p> <p>Microphone</p> <p>Patient monitor video and 9V dc power</p> <p>B/W printer video and remote control</p> <p>VGA monitor</p> <p>Parallel port</p> <p>USB</p>
Auxiliary	<p>Black-and white printer</p> <p>Color printer</p> <p>VCR</p> <p>Monitor</p> <p>Foot switch</p>

2 Safety

2.1 Overview

Chapter 2 contains the information necessary to Safety.











Contents Safety











2.1	Overview	2-1
2.2	Safety – Related Information	2-2
2.2.1	Safety Symbols	2-2
2.2.2	Label	2-4
2.3	Electrical Safety	2-6
2.3.1	Prevention Electric Shock	2-6
2.3.2	ECG – Related Information	2-7
2.3.3	ESD	2-8
2.3.4	EMI	2-8
2.3.5	EMC	2-9
2.4	Mechanical Safety	2-15
2.4.1	Moving the Equipment	2-15
2.4.2	Safety Note	2-16
2.5	Biological Safety	2-17
2.5.1	ALARA Principle	2-17
2.6	Environmental Protection	2-29

2.2 Safety – Related Information

2.2.1 Safety Symbols

The International Electro Technical Commission (IEC) has established a set of symbols for medical electronic equipment, which classifies a connection or warn of potential hazards. The classifications and symbols are shown below.

Symbols	Description
	Isolated patient connection (Type BF applied part).
	Power switch (Supplies/cuts the power for product)
	Indicates a caution for risk of electric shock.
	Indicates dangerous voltages over 1000V AC or over 1500V DC.
	Warning, Caution
	Identifies an equipotential ground.
	Identifies the point where the system safety ground is fastened to the chassis. Protective earth connected to conductive parts of Class I equipment for safety purposes.
	Electrostatic discharge
	Data Output port
	Data Input port
	Data Input/Output port

Symbols	Description
	Left and right Audio / Video input
	Left and right Audio / Video output
	Print remote output
	Foot switch connector
	ECG connector
	USB connector
	Microphone connector
	Protection against the effects of immersion.
	Protection against dripping water.
	Probe connector

2.2.2 Labels

To protect the system, you may see 'Warning' or 'Caution' marked on the surface of the product

1) Front

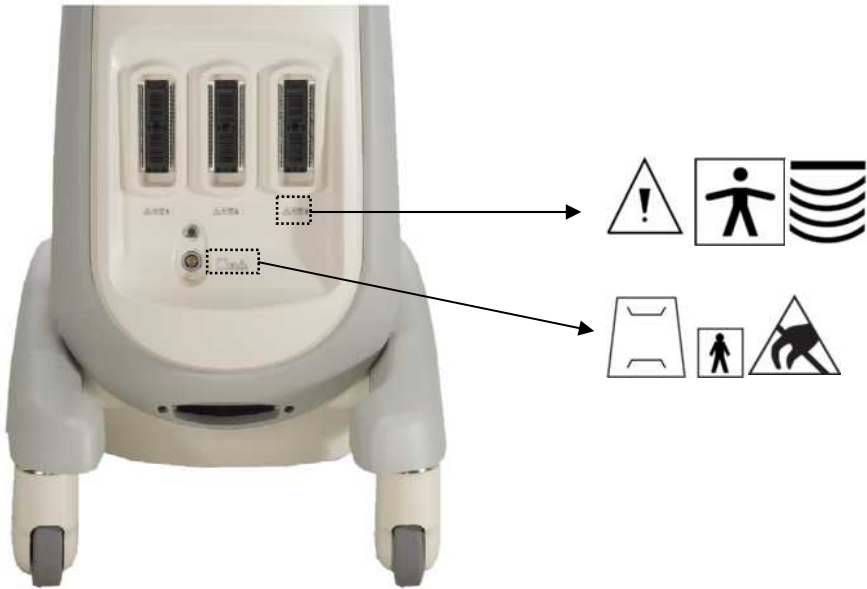

[Figure 2-1] Labels of Front

2) Rear

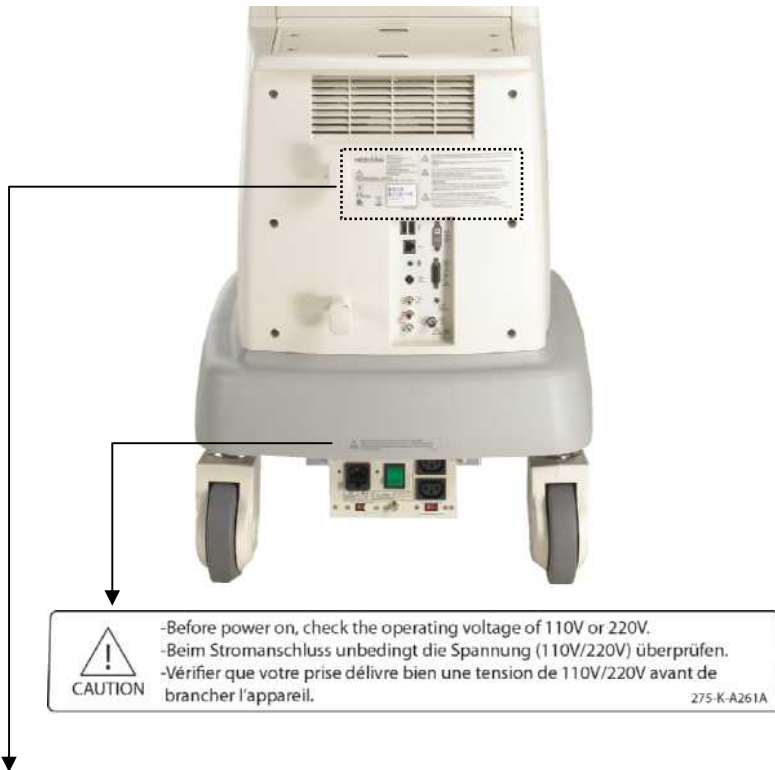

CAUTION !

-Before power on, check the operating voltage of 110V or 220V.
 -Beim Stromanschluss unbedingt die Spannung (110V/220V) überprüfen.
 -Vérifier que votre prise délivre bien une tension de 110V/220V avant de brancher l'appareil.

275-K-A261A

<p>MEDISON</p> <p>MODEL/MODELL/MODÈLE : SONOACE X6 POWER/NETZ/ALIMENTATION: 100-120/100-240V~, 8/5A, 50/60Hz</p> <p>CE 0123</p> <p>MADE IN KOREA</p>	<p>MEDISON CO., LTD. 109, Liachon-dong, Sangnam-gu, SEOUL, 152-280 KOREA www.MEDISON.COM</p> <p>EC REPRESENTATIVE (EC REPRÄSENTANT) (EC WIRTSCHAFTSVERTRÄGNER) SONOACE Deutschland GmbH Elisenweg 14, D-45764 Muel, Deutschland www.sonace.de</p>	<p>CAUTION !</p> <p>Please keep this operation manual close to the product as a reference when using the system. Bewahren Sie bitte diese Bedienungsanleitung bei der Benutzung als Referenz in der Nähe des Gerätes auf. Veuillez conserver ce manuel comme référence à proximité du produit lors de l'utilisation du système.</p> <p>CAUTION !</p> <p>Make sure that peripheral devices and probes are securely fastened to the cart. Confirm the status of the peripherals and probes. These should be firmly attached. Move the cart slowly after checking the brakes. Überprüfen Sie, ob die Peripheriegeräte und Sonden sicher am Wagen befestigt sind. Sie müssen vollständig fixiert sein. Lösen Sie ggf. die Bremsen, und bewegen Sie den Wagen langsam. Vérifier que les périphériques et les sondes sont correctement fixés au chariot de transport. Confirmer l'état des périphériques et des sondes. Ceux-ci doivent être parfaitement fixés. Déplacer lentement le chariot de transport après avoir vérifié les freins des roues.</p> <p>WARNING !</p> <p>Do not remove the system's covers; hazardous voltages are present inside. The cabinet panels must be in place while the system is in use. Öffnen Sie das Gerät nicht; im Inneren gibt es lebensgefährliche elektrische Spannungen. Das Gerät darf nur vollständig und ungeöffnet betrieben werden. Ne pas enlever les panneaux de protection du système; il y a de l'électricité à l'intérieur. Ces panneaux de protection doivent être en place quand le système est en marche.</p> <p>275-K-A261A</p>
--	--	--

[Figure 2-2] Labels of Rear

2.3 Electrical Safety

This equipment has been verified as a Class I device with Type BF applied parts.

2.3.1 Prevention of Electric Shock

In a hospital, dangerous currents are due to the potential differences between connected equipment and touchable conducting parts found in medical rooms. The solution to the problem is consistent equipotential bonding. Medical equipment is connected with connecting leads made up of angled sockets to the equipotential bonding network in medical rooms.

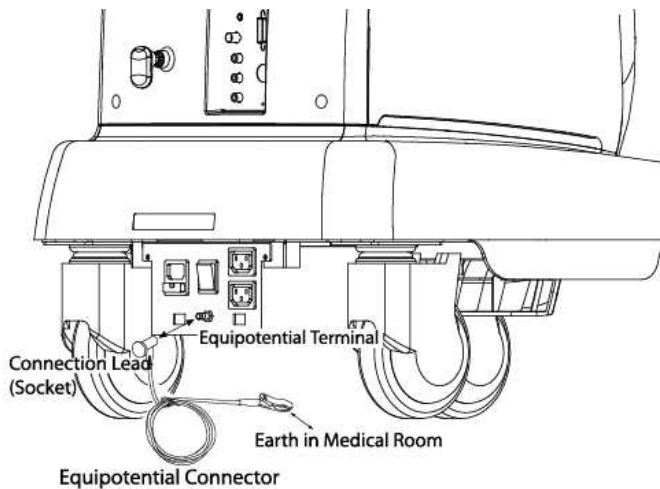

[Figure 2–3] Equipotential bonding

Additional equipment connected to medical electrical equipment must comply with the respective IEC or ISO standards (e.g. IEC 60950 for data processing equipment). Furthermore all configurations shall comply with the requirements for medical electrical systems (see IEC 60601–1–1 or clause 16 of the 3 Ed. of IEC 60601–1, respectively). Anybody connecting additional equipment to medical electrical equipment configures a medical system and is therefore responsible that the system complies with the requirements for medical electrical systems. Attention is drawn to the fact that local laws take priority over the above-mentioned requirements. If in doubt, consult your local distributor or the technical service department.

WARNING

- Electric shock may exist result if this system, including and all of its externally mounted recording and monitoring devices, is not properly grounded.
- Do not remove the covers on the system; hazardous voltages are present inside. Cabinet panels must be in place while the system is in use. All internal adjustments and replacements must be made by a qualified MEDISON Customer Service Department.
- Check the face, housing, and cable before use. Do not use, if the face is cracked, chipped, or torn, the housing is damaged, or if the cable is abraded.
- Always disconnect the system from the wall outlet prior to cleaning the system.
- All patient contact devices, such as probes and ECG leads, must be removed from the patient prior to application of a high voltage defibrillation pulse.
- The use of flammable anesthetic gas or oxidizing gases (N2O) should be avoided.

CAUTION

- The system has been designed for 100–120VAC and 200–240VAC; you should select the input voltage of monitor, printer and VCR. Prior to connecting an OEM power cord, verify that the voltage indicated on the power cord matches the voltage rating of the OEM device.
- An isolation transformer protects the system from power surges. The isolation transformer continues to operate when the system is in standby.
- Do not immerse the cable in liquids. Cables are not waterproof.
- The operator does not contact the parts (SIP/SOP) and the patient simultaneously

2.3.2 ECG-Related Information

WARNING

- This device is not intended to provide a primary ECG monitoring function, and therefore does not have means of indicating an inoperative electrocardiograph.
- Do not use ECG electrodes of HF surgical equipment. Any malfunctions in the HF surgical equipment may result in burns to the patient.
- Do not use ECG electrodes during cardiac pacemaker procedures or other electrical stimulators.
- Do not use ECG leads and electrodes in an operating room.

2.3.3 ESD

Electrostatic discharge (ESD), commonly referred to as a static shock, is a naturally occurring phenomenon. ESD is most prevalent during conditions of low humidity, which can be caused by heating or air conditioning. During low humidity conditions, electrical charges naturally build up on individuals, creating static electricity. An ESD occurs when an individual with an electrical energy build-up comes in contact with conductive objects such as metal doorknobs, file cabinets, computer equipment, and even other individuals. The static shock or ESD is a discharge of the electrical energy build-up from a charged individual to a lesser or non-charged individual or object.

The ESD caution symbol is on the probe connector and the rear panel.



[Figure 2-4] ESD symbol

CAUTION



- The level of electrical energy discharged from a system user or patient to an ultrasound system can be significant enough to cause damage to the system or probes.
- The following precautions can help to reduce ESD:
 - Anti-static sprays on carpets or linoleum
 - Anti-static mats
 - A ground wire connection between the system and the patient table or bed.

2.3.4 EMI

Although this system has been manufactured in compliance with existing EMI (Electromagnetic Interference) requirements, use of this system in the presence of an electromagnetic field can cause momentary degradation of the ultrasound image.

If this occurs often, MEDISON suggests a review of the environment in which the system is being used, to identify possible sources of radiated emissions. These emissions could be from other electrical devices used within the same room or an adjacent room. Communication devices such as cellular phones and pagers can cause these emissions. The existence of radios, TVs, or microwave transmission equipment nearby can also cause interference.

CAUTION

In cases where EMI is causing disturbances, it may be necessary to relocate this system.

2.3.5 EMC

The testing for EMC(Electromagnetic Compatibility) of this system has been performed according to the international standard for EMC with medical devices (IEC60601-1-2). This IEC standard was adopted in Europe as the European norm (EN60601-1-2).

2.3.5.1 Guidance and manufacturer's declaration – electromagnetic emission

This product is intended for use in the electromagnetic environment specified below. The customer or the user of this product should assure that it is used in such an environment.

Emission test	Compliance	Electromagnetic environment –guidance
RF Emission (Radiation) CISPR 11	Group 1 Class B	The Ultrasound System uses RF energy only for its internal function. Therefore, its RF emissions are very low and are not likely to cause any interference in nearby electronic equipment. The Ultrasound System is suitable for use in all establishments, including domestic establishments and those directly connected to the public low-voltage power supply network that supplies building used for domestic purpose.
RF Emission (Radiation) CISPR 11	Group 1 Class B	
Harmonic Emission IEC 61000-3-2	Class A	
Flicker Emission IEC 61000-3-3	Complies	

2.3.5.2 Approved Cables, Transducers and Accessories for EMC

1) Approved Cable for Electromagnetic Compliance

Cables connected to this product may affect its emissions:
Use only the cable types and lengths listed below table.

Cable	Type	Length
VGA	Shielded	Normal
Parallel	Shielded	Normal
RS232C	Shielded	Normal
USB	Shielded	Normal
LAN(RJ45)	Twisted pair	Any
S-Video	Shielded	Normal
Foot Switch	Shielded	2.5m
B/W Printer	Unshielded Coaxial	Normal
MIC	Unshielded	Any
Printer Remote	Unshielded	Any
Audio R.L	Shielded	Normal
VHS	Shielded	Normal
ECG AUX input	Shielded	< 3m

2) Approved Transducer for Electromagnetic Compliance

The probe listed in ‘Chapter 8. Probes’ when used with this product, have been tested to comply with the group1 class B emission as required by International Standard CISPR 11.

3) Approved Accessories for Electromagnetic Compliance

Accessories used with this product may effect its emissions.

CAUTION



When connecting other customer-supplied accessories to the system, such as a remote printer or VCR, it is the user’s responsibility to ensure the electromagnetic compatibility of the system. Use only CISPR 11 or CISPR 22, CLASS B compliant devices.

Immunity test	IEC 60601 Test level	Compliance level	Electromagnetic environment – guidance
Electrostatic discharge (ESD) IEC 61000-4-2	±6KV Contact ±8KV air	±6KV Contact ±8KV air	Floors should be wood, concrete or ceramic tile. If floors are covered with synthetic material, the relative humidity should be at least 30%.
Electrical fast transient/burst IEC 61000-4-4	±2KV for power supply lines ±1KV for input/output lines	±2KV for power supply lines ±1KV for input/output lines	Mains power quality should be that of a typical commercial or hospital environment.
Surge IEC 61000-4-5	±1KV differential mode ±2KV common mode	±1KV differential mode ±2KV common mode	Mains power quality should be that of a typical commercial or hospital environment.
Voltage dips, short interruptions and voltage variations on power supply input lines IEC 61000-4-11	<5% U_T (>95% dip in U_T) for 0.5cycle 40% U_T (60% dip in U_T) for 5 cycle 70% U_T (30% dip in U_T) for 25 cycle <5% U_T (<95% dip in U_T) for 5 s	<5% U_T (>95% dip in U_T) for 0.5cycle 40% U_T (60% dip in U_T) for 5 cycle 70% U_T (30% dip in U_T) for 25 cycle <5% U_T (<95% dip in U_T) for 5 s	Mains power quality should be that of a typical commercial or hospital environment. If the user of this product requires continued operation during power mains interruptions, it is recommended that this product be powered from an uninterruptible power supply or a battery.
Power frequency (50/60Hz) magnetic field IEC 61000-4-8	3 A/m	3 A/m	Power frequency magnetic fields should be at levels characteristic of a typical location in a typical commercial or hospital environment.
NOTE U_T is the a.c. mains voltage prior to application of the test level.			

<p>Conducted RF IEC 61000-4-6</p>	<p>3 Vrms 150 kHz to 80MHz</p>	<p>0.01V</p>	<p>Portable and mobile RF communications equipment should be used no closer to any part of the Ultrasound System, including cables, than the recommended separation distance calculated from the equation applicable to the frequency of the transmitter.</p> <p>Recommended separation distance</p> $d = \left[\frac{3,5}{V_1} \right] \sqrt{P}$ $d = \left[\frac{3,5}{E_1} \right] \sqrt{P}$ <p style="text-align: right;">80MHz to 800MHz</p> $d = \left[\frac{7}{E_1} \right] \sqrt{P}$ <p style="text-align: right;">800MHz to 2.5GHz</p> <p>Where P is the maximum output power rating of the transmitter in watts (W) according to the transmitter manufacturer and d is the recommended separation distance in meters (m).</p> <p>Field strengths from fixed RF transmitters, as determined by an electromagnetic site survey, ^a should be less than the compliance level in each frequency range. ^b</p> <p>Interference may occur in the vicinity of equipment marked with the following symbol :</p> 
<p>NOTE 1) At 80MHz and 800MHz, the higher frequency range applies. NOTE 2) These guidelines may not apply in all situations. Electromagnetic propagation is affected by absorption and reflection from structures, objects and people.</p>			
<p>^a Field strengths from fixed transmitters, such as base stations for radio (cellular/cordless) telephones and land mobile radios, amateur radio, AM and FM radio broadcast and TV broadcast cannot be predicted theoretically with accuracy. To assess the electromagnetic environment due to fixed RF transmitters, an electromagnetic site survey should be considered. If the measured field strength in the location in which the Ultrasound System is used exceeds the applicable RF compliance level above, the Ultrasound System should be observed to verify normal operation. If abnormal performance is observed, additional measures may be necessary, such as re-orienting or relocating the Ultrasound System or using a shielded location with a higher RF shielding effectiveness and filter attenuation.</p> <p>^b Over the frequency range 150kHz to 80MHz, field strengths should be less than $[V_1]$ V/m.</p>			

2.3.5.3 Recommended separation distances between portable and mobile RF communications equipment and the SONOACE X6

This product is intended for use in an electromagnetic environment in which radiated RF disturbances are controlled. The customer or the user of this product can help Prevent electromagnetic interference by maintaining a minimum distance between portable and mobile RF communications equipment (transmitters) and this product as recommended below, according to the maximum output power of the communications equipment.

Rated maximum output power of transmitter [W]	Separation distance according to frequency of transmitter [m]		
	150kHz to 80MHz $d = \left[\frac{3,5}{V_1} \right] \sqrt{P}$	80MHz to 800MHz $d = \left[\frac{3,5}{E_1} \right] \sqrt{P}$	800MHz to 2.5GHz $d = \left[\frac{7}{E_1} \right] \sqrt{P}$
	V1=0.01Vrms	E1=3 V/m	E1=3V/m
0.01	35.00	0.11	0.23
0.1	110.68	0.36	0.73
1	350.00	1.16	2.33
10	1106.80	3.68	7.37
100	3500.00	11.66	23.33

For transmitters rated at a maximum output power not listed above, the recommended separation distance d in meters (m) can be estimated using the equation applicable to the frequency of the transmitter, where p is the maximum output power rating of the transmitter in watts (W) according to the transmitter manufacturer.

NOTE 1) At 80MHz and 800MHz, the separation distance for the higher frequency range applies.

NOTE 2) These guidelines may not apply in all situations. Electromagnetic propagation is affected by absorption and reflection from structures, objects and people.

2.3.5.4 Electromagnetic environment – guidance

The Ultrasound System must be used only in a shielded location with a minimum RF shielding effectiveness and, for each cable that enters the shielded location. Field strengths outside the shielded location from fixed RF transmitters, as determined by an electromagnetic site survey, should be less than 3V/m.

It is essential that the actual shielding effectiveness and filter attenuation of the shielded location be verified to assure that they meet the minimum specification.

CAUTION



If the system is connected to other customer-supplied equipment, such as a local area network (LAN) or a remote printer, Medison cannot guarantee that the remote equipment will work correctly in the presence of electromagnetic phenomena.

2.3.5.5 Avoiding Electromagnetic Interference

A medical device can either generate or receive electromagnetic interference. The EMC standards describe tests for both emitted and received interference.

Medison Ultrasound System does not generate interference in excess of the referenced standards.

An Ultrasound System is designed to receive signals at radio frequency and is therefore susceptible to interference generated by RF energy sources. Examples of other source of interference are medical device, information technology products, and radio and television transmission towers. Tracing the source of radiated interference can be a difficult task. Customers should consider the following in an attempt to locate the source:

- Is the interference intermittent or constant?
- Does the interference show up only with one transducers operating at the same frequency or with several transducer?
- Do two different transducer operating at the same frequency have the same problem?
- Is the interference present if the system is moved to a different location in the facility?

The answers to these questions will help determine if the problem reside with the system or the scanning environment. After you answer the question, contact your local MEDISON customer service department.

2.4 Mechanical Safety

2.4.1 Moving the Equipment

Before transporting the product, check that the brakes on the front wheels are unlocked. Also, make sure to retract the monitor arm completely so that it is secured in a stationary position.

Always use the handles at the back of the console and move the product slowly.

This product is designed to resist shocks. However, excessive shock, for example if the product falls over, may cause serious damage.

If the system operates abnormally after repositioning, please contact the MEDISON Customer Service Department.

WARNING



The product weighs more than 60kg. Be extra careful when transporting it.

Careless transportation of the product may result in product damage or personal injury

2.4.1.1 The Brakes

Brakes are mounted to the front wheels of the console only. To lock the brakes, press the top part of the brake with your foot. To unlock them, press the part labeled Off at the bottom of the brake with your foot.

You can use the brakes to control the movement of the product. We recommend that you lock the brakes when using the product.

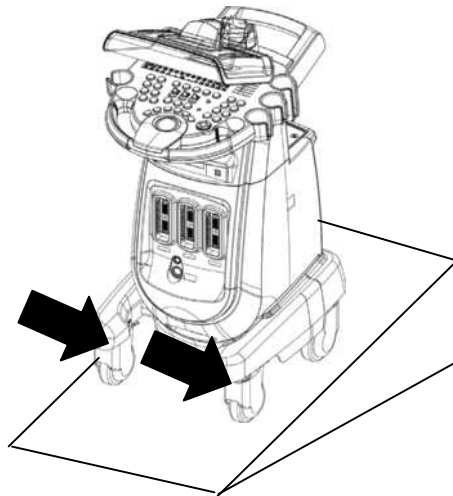

[Figure 2-5] Precautions on Ramps

2.4.1.2 Precautions on Ramps

Always make sure that control panel is facing the direction of movement

When moving the product down a ramp or resting it temporarily on a ramp, the product may tilt over even with the brakes on depending on the direction of the product. Do not rest the product on ramps.

WARNING



Be aware of the castors, especially when moving the system. MEDISON recommends that you exercise caution when moving the product up or down ramps

2.4.2 Safety Note

CAUTION



- Do not press the control panel excessively.
- Never attempt to modify the product in any way.
- Check the operational safety when using the product after a prolonged break in service.
- Make sure that other objects, such as metal pieces, do not enter the system.
- Do not block the ventilation slots.
- To prevent damage to the power cord, be sure to grip the plug head – not the cord – when unplugging.
- Excessive bending or twisting of cables on patient-applied parts may cause failure or intermittent operation of the system.
- Improper cleaning or sterilization of a patient-applied part may cause permanent damage.

2.5 Biological Safety

Verify the alignment of the Probe before use. See the “Chapter 9. Probes” section of this manual.

WARNING



- Ultrasound waves may have damaging effects on cells and, therefore, may be harmful to the patient. If there is no medical benefit, minimize the exposure time and maintain the ultrasound wave output level at low. Please refer to the ALARA principle.
- Do not use the system if an error message appears on the video display indicating that a hazardous condition exists. Note the error code, turn off the power to the system, and call your local MEDISON Customer Service Department.
- Do not use a system that exhibits erratic or inconsistent updating. Discontinuities in the scanning sequence are indicative of a hardware failure that should be corrected before use.
- The system limits the maximum contact temperature to 43 degree Celsius, and the ultrasonic waves output observes American FDA regulations.

2.5.1 ALARA Principle

Guidance for the use of diagnostic ultrasound is defined by the “as low as reasonably achievable” (ALARA) principle. The decision as to what is reasonable has been left to the judgment and insight of qualified personnel. No set of rules can be formulated that would be sufficiently complete to dictate the correct response for every circumstance. By keeping ultrasound exposure as low as possible, while obtaining diagnostic images, users can minimize ultrasonic bioeffects.

Since the threshold for diagnostic ultrasound bioeffects is undetermined, it is the sonographer’s responsibility to control the total energy transmitted into the patient. The sonographer must reconcile exposure time with diagnostic image quality. To ensure diagnostic image quality and limit exposure time, the ultrasound system provides controls that can be manipulated during the exam to optimize the results of the exam.

The ability of the user to abide by the ALARA principle is important. Advances in diagnostic ultrasound not only in the technology but also in the applications of the technology, have resulted in the need for more and better information to guide the user. The output indices are designed to provide that important information. There are a number of variables, which affect the way in which the output display indices can be used to implement the ALARA principle. These variables include mass, body size, location of the bone relative to the focal point, attenuation in the body, and ultrasound exposure time. Exposure time is an especially useful variable, because the user controls it. The ability to limit the index values over time support the ALARA principle.

2.5.1.1 Applying ALARA

The system-imaging mode used depends upon the information needed. 2D-mode and M-mode imaging provide anatomical information, while Doppler, Power, and Color imaging provide information about blood flow. Scanned modes, like 2D-mode, Power, or Color, disperse or scatter the ultrasonic energy over an area, while an unscanned mode, like M-mode or Doppler, concentrates ultrasonic energy. Understanding the nature of the imaging mode being used allows the sonographer to apply the ALARA principle with informed judgment. The probe frequency, system set-up values, scanning techniques, and operator experience aid the sonographer in meeting the definition of the ALARA principle.

The decision as to the amount of acoustic output is, in the final analysis, up to the system operator. This decision must be based on the following factors: type of patient, type of exam, patient history, ease or difficulty of obtaining diagnostically useful information, and the potential localized heating of the patient due to probe surface temperatures. Prudent use of the system occurs when patient exposure is limited to the lowest index reading for the shortest amount of time necessary to achieve acceptable diagnostic results.

Although a high index reading does not mean that a bioeffect is actually occurring, a high index reading should be taken seriously. Every effort should be made to reduce the possible effects of a high index reading. Limiting exposure time is an effective way to accomplish this goal.

There are several system controls that the operator can use to adjust the image quality and limit the acoustic intensity. These controls are related to the techniques that an operator might use to implement ALARA. These controls can be divided into three categories: direct, indirect, and receiver control.

2.5.1.2 Direct Controls

Application selection and the output intensity control directly affect acoustic intensity. There are different ranges of allowable intensity or output based on your selection. Selecting the correct range of acoustic intensity for the application is one of the first things required during any exam. For example, peripheral vascular intensity levels are not recommended for fetal exams. Some systems automatically select the proper range for a particular procedure, while others require manual selection. Ultimately, the user bears the responsibility for proper clinical use. The MEDISON system provides both automatic and user-definable settings.

Output has direct impact on acoustic intensity. Once the application has been established, the output control can be used to increase or decrease the intensity output. The output control allows you to select intensity levels less than the defined maximum. Prudent use dictates that you select the lowest output intensity consistent with good image quality.

2.5.1.3 Indirect Controls

The indirect controls are those that have an indirect effect on acoustic intensity. These controls affect imaging mode, pulse repetition frequency, focus depth, pulse length, and probe selection.

The choice of imaging mode determines the nature of the ultrasound beam. 2D-mode is a scanning mode, Doppler is a stationary or unscanned mode. A stationary ultrasound beam concentrates energy on a single location. A moving or scanned ultrasound beam disperses the energy over a wide area and the beam is only concentrated on a given area for a fraction of the time necessary in unscanned mode.

Pulse repetition frequency or rate refers to the number of ultrasound bursts of energy over a specific period of time. The higher the pulse repetition frequency, the more pulses of energy in a given period of time. Several controls affect pulse repetition frequency: focal depth, display depth, sample volume depth, color sensitivity, number of focal zones, and sector width controls.

Focus of the ultrasound beam affects the image resolution. To maintain or increase resolution at a different focus requires a variation in output over the focal zone. This variation of output is a function of system optimization. Different exams require different focal depths. Setting the focus to the proper depth improves the resolution of the structure of interest.

Pulse length is the time during which the ultrasonic burst is turned on. The longer the pulse, the greater the time-average intensity value. The greater the time-average intensity, the greater the likelihood of temperature increase and cavitations. Pulse length or burst length or pulse duration is the output pulse duration in pulsed Doppler. Increasing the Doppler sample volume increases the pulse length.

Probe selection affects intensity indirectly. Tissue attenuation changes with frequency. The higher the probe operating frequency, the greater the attenuation of the ultrasonic energy. Higher probe operating frequencies require higher output intensity to scan at a deeper depth. To scan deeper at the same output intensity, a lower probe frequency is required. Using more gain and output beyond a point, without corresponding increases in image quality, can mean that a lower frequency probe is needed.

2.5.1.4 Receiver Controls

Receiver controls are used by the operator to improve image quality. These controls have no effect on output. Receiver controls only affect how the ultrasound echo is received. These controls include gain, TGC, dynamic range, and image processing. The important thing to remember, relative to output, is that receiver controls should be optimized before increasing output. For example; before increasing output, optimize gain to improve image quality.

2.5.1.5 Additional Considerations

Ensure that scanning time is kept to a minimum, and ensure that only medically required scanning is performed. Never compromise quality by rushing through an exam. A poor exam will require a follow-up, which ultimately increases the time. Diagnostic ultrasound is an important tool in medicine, and, like any tool, should be used efficiently and effectively.

2.5.1.6 Output Display Features

The system output display comprises two basic indices: a mechanical index and a thermal index. The thermal index consists of the following indices: soft tissue (TIs), bone (Tlb) and cranial bone (Tlc). One of these three thermal indices will be displayed at all times. Which one depends upon the system preset or user choice, depending upon the application at hand.

The mechanical index is continuously displayed over the range of 0.0 to 1.9, in increments of 0.1.

The thermal index consists of the three indices, and only one of these is displayed at any one time. Each probe application has a default selection that is appropriate for that combination. The Tlb or TIs is continuously displayed over the range of 0.0 to maximum output, based on the probe and application, in increments of 0.1.

The application-specific nature of the default setting is also an important factor of index behavior. A default setting is a system control state which is preset by the manufacturer or the operator. The system has default index settings for the probe application. The default settings are invoked automatically by the ultrasound system when power is turned on, new patient data is entered into the system database, or a change in application takes place.

The decision as to which of the three thermal indices to display should be based on the following criteria:

Appropriate index for the application: TIs is used for imaging soft tissue; and Tlb for a focus at or near bone. Some factors might create artificially high or low thermal index readings e.g. presence of fluid or bone, or the flow of blood. A highly attenuating tissue path, for example, will cause the potential for local zone heating to be less than the thermal index displays.

Scanned modes versus unscanned modes of operation affect the thermal index. For scanned modes, heating tends to be near the surface; for unscanned modes, the potential for heating tends to be deeper in the focal zone.

Always limit ultrasound exposure time. Do not rush the exam. Ensure that the indices are kept to a minimum and that exposure time is limited without compromising diagnostic sensitivity.

1) Mechanical Index (MI) Display

Mechanical bioeffects are threshold phenomena that occur when a certain level of output is exceeded. The threshold level varies, however, with the type of tissue. The potential for mechanical bioeffects varies with peak pressure and ultrasound frequency. The MI accounts for these two factors. The higher the MI value, the greater the likelihood of mechanical bioeffects occurring but there is no specific MI value that means that a mechanical effect will actually occur. The MI should be used as a guide for implementing the ALARA principle

2) Thermal Index (TI) Display

The TI informs the user about the potential for temperature increase occurring at the body surface, within body tissue, or at the point of focus of the ultrasound beam on bone. The TI is an estimate of the temperature increase in specific body tissues. The actual amount of any temperature rise is influenced by factors such as tissue type, vascularity, and mode of operation etc. The TI should be used as a guide for implementing the ALARA principle.

The bone thermal index (Tlb) informs the user about potential heating at or near the focus after the ultrasound beam has passed through soft tissue or fluid, for

example, at or near second or third trimester fetal bone.

The cranial bone thermal index (Tlc) informs the user about the potential heating of bone at or near the surface, for example, cranial bone.

The soft tissue thermal index (TIs) informs the user about the potential for heating within soft homogeneous tissue.

You can select either TIs or TIb using the TIs/TIb selection on the Miscellaneous system setups. Tlc is displayed when you select a trans-cranial application.

3) Mechanical and Thermal indices Display Precision and Accuracy

The Mechanical and Thermal Indices on the system are precise to 0.1 units.

The MI and TI display accuracy estimates for the system are given in the Acoustic Output Tables manual. These accuracy estimates are based on the variability range of probes and systems, inherent acoustic output modeling errors and measurement variability, as described below.

The displayed values should be interpreted as relative information to help the system operator achieve the ALARA principle through prudent use of the system.

The values should not be interpreted as actual physical values investigated tissue or organs. The initial data that is used to support the output display is derived from laboratory measurements based on the AIUM measurement standard. The measurements are then put into algorithms for calculating the displayed output values.

Many of the assumptions used in the process of measurement and calculation are conservative in nature. Over-estimation of actual in situ exposure, for the vast majority of tissue paths, is built into the measurement and calculation process. For example:

The measured water tank values are de-rated using a conservative, industry standard, attenuation coefficient of 0.3dB/cm-MHz.

Conservative values for tissue characteristics were selected for use in the TI models. Conservative values for tissue or bone absorption rates, blood perfusion rates, blood heat capacity, and tissue thermal conductivity were selected. Steady state temperature rise is assumed in the industry standard TI models, and the assumption is made that the ultrasound probe is held steady in one position long enough for steady state to be reached.

A number of factors are considered when estimating the accuracy of display values: hardware variations, algorithm accuracy estimation and measurement variability. Variability among probes and systems is a significant factor. Probe variability results from piezoelectric crystal efficiencies, process-related impedance differences, and sensitive lens focusing parameter variations. Differences in the system pulse voltage control and efficiencies are also a contributor to variability. There are inherent uncertainties in the algorithms used for estimating acoustic output values over the range of possible system operating conditions and pulse voltages. Inaccuracies in laboratory measurements are related to differences in hydrophone calibration and performance, positioning, alignment and digitization tolerances, and variability among test operators.

The conservative assumptions of the output estimation algorithms of linear propagation, at all depths, through a 0.3dB/cm-MHz attenuated medium are not taken into account in calculation of the accuracy estimate displayed. Neither linear propagation, nor uniform attenuation at the 0.3dB/cm-MHz rate, occurs in water tank measurements or in most tissue paths in the body. In the body,

different tissues and organs have dissimilar attenuation characteristics. In water, there is almost no attenuation. In the body, and particularly in water tank measurements, non-linear propagation and saturation losses occur as pulse voltages increase.

The display accuracy estimates take into account the variability ranges of probes and systems, inherent acoustic output modeling errors, and measurement variability. Display accuracy estimates are not based on errors in, or caused by measuring according to, the AIUM measurement standards. They are also independent of the effects of non-linear loss on the measured values.

2.5.1.7 Control Affecting the indices

As various system controls are adjusted, the TI and MI values may change. This will be most apparent as the POWER control is adjusted; however, other system controls will affect the on-screen output values.

1) POWER

Power controls the system acoustic output. Two real-time output values are on the screen: a TI and a MI. They change as the system responds to POWER adjustments.

In combined modes, such as simultaneous Color, 2D-mode and pulsed Doppler, the individual modes each add to the total TI. One mode will be the dominant contributor to this total. The displayed MI will be from the mode with the largest peak pressure.

2.5.1.8 2D Mode Controls

1) 2D-mode size

Narrowing the sector angle may increase the frame rate. This action will increase the TI. Pulse voltage may be automatically adjusted down with software controls to keep the TI below the system maximums. A decrease in pulse voltage will decrease MI.

2) Zoom

Increasing the zoom magnification may increase frame rate. This action will increase the TI. The number of focal zones may also increase automatically to improve resolution. This action may change MI since the peak intensity can occur at a different depth.

3) Persistence

A lower persistence will decrease the TI. Pulse voltage may be automatically increased. An increase in pulse voltage will increase MI.

4) Focal no.

More focal zones may change both the TI and MI by changing frame rate or focal depth automatically. Lower frame rates decrease the TI. MI displayed will correspond to the zone with the largest peak intensity.

5) Focus

Changing the focal depth will change the MI. Generally, higher MI values will occur when the focal depth is near the natural focus of the transducer.

2.5.1.9 Color and Power Controls

1) Color Sensitivity

Increasing the color sensitivity may increase the TI. More time is spent scanning for color images.

Color pulses are the dominant pulse type in this mode.

2) Color Sector Width

Narrower color sector width will increase color frame rate and the TI will increase. The system may automatically decrease pulse voltage to stay below the system maximum. A decrease in pulse voltage will decrease the MI. If pulsed Doppler is also enabled then pulsed Doppler will remain the dominant mode and the TI change will be small.

3) Color Sector Depth

Deeper color sector depth may automatically decrease color frame rate or select a new color focal zone or color pulse length. The TI will change due to the combination of these effects. Generally, the TI will decrease with increased color sector depth. MI will correspond to the peak intensity of the dominant pulse type, which is a color pulse. However, if pulsed Doppler is also enabled then pulsed Doppler will remain the dominant mode and the TI change will be small.

4) Scale

Using the SCALE control to increase the color velocity range may increase the TI. The system will automatically adjust pulse voltage to stay below the system maximums. A decrease in pulse voltage will also decrease MI.

5) Sec Width

A narrower 2D-mode sector width in Color imaging will increase color frame rate. The TI will increase. MI will not change. If pulsed Doppler is also enabled, then pulsed Doppler will remain as the primary mode and the TI change will be small.

2.5.1.10 M mode and Doppler Controls

1) Speed

M-mode and Doppler sweep speed adjustments will not affect the MI. When M-mode sweep speed changes, TI changes.

2) Simultaneous and Update Methods

Use of combination modes affects both the TI and MI through the combination of pulse types. During simultaneous mode, the TI is additive. During auto-update and duplex, the TI will display the dominant pulse type. The displayed MI will be from the mode with the largest peak pressure.

3) Sample Volume Depth

When Doppler sample volume depth is increased the Doppler PRF may automatically decrease. A decrease in PRF will decrease the TI. The system may also automatically decrease the pulse voltage to remain below the system maximum. A decrease in pulse voltage will decrease MI.

2.5.1.11 DOPPLER, CW, M MODE, and COLOR Imaging Controls

When a new imaging mode is selected, both the TI and the MI will change to default settings. Each mode has a corresponding pulse repetition frequency and maximum intensity point. In combined or simultaneous modes, the TI is the sum of the contribution from the modes enabled and MI is the MI for the focal zone and mode with the largest derated intensity. If a mode is turned off and then reselected, the system will return to the previously selected settings.

1) Probe

Each probe model available has unique specifications for contact area, beam shape, and center frequency. Defaults are initialized when you select a probe. MEDISON factory defaults vary with probe, application, and selected mode. Defaults have been chosen below the FDA limits for intended use.

2) Depth

An increase in 2D-mode depth will automatically decrease the 2D-mode frame rate. This would decrease the TI. The system may also automatically choose a deeper 2D-mode focal depth. A change of focal depth may change the MI. The MI displayed is that of the zone with the largest peak intensity.

3) Application

Acoustic output defaults are set when you select an application. MEDISON factory defaults vary with probe, application, and mode. Defaults have been chosen below the FDA limits for intended use.

2.5.1.12 Related Guidance Documents

For more information about ultrasonic bioeffects and related topics refer to the following:

- AIUM Report, January 28, 1993, "Bioeffects and Safety of Diagnostic Ultrasound"
- Bioeffects Considerations for the Safety of Diagnostic Ultrasound, J Ultrasound Med., Sept. 1998: Vol. 7, No. 9 Supplement
- Acoustic Output Measurement Standard for Diagnostic Ultrasound Equipment. (AIUM, NEMA. 1998)
- Acoustic Output Labeling Standard for Diagnostic Ultrasound Equipment (AIUM, 1998)
- Second Edition of the AIUM Output Display Standard Brochure, Dated March 10, 1994. (A copy of this document is shipped with each system.)
- Information for Manufacturer Seeking Marketing Clearance of Diagnostic Ultrasound Systems and Transducers. FDA. September 1997. FDA.
- Standard for Real-Time Display of Thermal and Mechanical Acoustic Output Indices on Diagnostic Ultrasound Equipment. (Revision 1, AIUM, NEMA. 1998)
- WFUMB. Symposium on Safety of Ultrasound in Medicine: Conclusions and Recommendations on Thermal and Non-Thermal Mechanisms for Biological Effects of Ultrasound, Ultrasound in Medicine and Biology, 1998: Vol. 24, Supplement 1.

2.5.1.13 Acoustic Output and Measurement

Since the first usage of diagnostic ultrasound, the possible human biological effects (bioeffects) of ultrasound exposure have been studied by various scientific and medical institutions. In October 1987, the American Institute of Ultrasound in Medicine (AIUM) ratified a report prepared by its Bioeffects Committee (Bioeffects Considerations for the Safety of Diagnostic Ultrasound, J Ultrasound Med., Sept. 1988: Vol.7, No.9 Supplement), sometimes referred to as the Stowe Report, which reviewed available data on possible effects of ultrasound exposure. Another report "Bioeffects and Safety of Diagnostic Ultrasound," dated January 28, 1993 provides more up to date information.

The acoustic output for this system has been measured and calculated in accordance with the December 1985 "510(K) Guide for Measuring and Reporting Acoustic Output of Diagnostic Ultrasound Medical Devices," except that the hydrophone meets the requirements of "Acoustic Output Measurement Standard for Diagnostic Ultrasound Equipment" (NEMA UD 2-1992)

2.5.1.14 In Situ, Derated, and Water Value Intensities

All intensity parameters are measured in water. Since water does not absorb acoustic energy, these water measurements represent a worst case value. Biological tissue does absorb acoustic energy. The true value of the intensity at any point depends on the amount and type of tissue and the frequency of the ultrasound that passes through the tissue. The intensity value in the tissue, *In Situ*, has been estimated using the following formula:

$$\text{In Situ} = \text{Water} [e^{-(0.23alf)}]$$

where: In Situ = In Situ Intensity Value

Water = Water Value Intensity

$e = 2.7183$

a = Attenuation Factor

Tissue	$a(\text{dB}/\text{cm}-\text{MHz})$
Brain	.53
Heart	.66
Kidney	.79
Liver	.43
Muscle	.55

Brain .53

Heart .66

Kidney .79

Liver .43

Muscle .55

l = skin line to measurement depth (cm)

f = Center frequency of the transducer/system/mode combination(MHz)

Since the ultrasonic path during an examination is likely to pass through varying lengths and types of tissue, it is difficult to estimate the true *In Situ* intensity. An attenuation factor of 0.3 is used for general reporting purpose; therefore, the *In Situ* value which is commonly reported uses the formula:

$$\text{In Situ (derated)} = \text{Water} [e^{-(0.069lf)}]$$

Since this value is not the true *In Situ* intensity, the term "derated" is used.

The maximum derated and the maximum water values do not always occur at the

same operating condition; therefore, the reported maximum water and derated values may not be related to the *In Situ* (derated) formula. Take for example a multi-zone array transducer that has maximum water value intensities in its deepest zone: the same transducer may have its largest derated intensity in one of its shallowest focal zones.

2.5.1.15 Acoustic Output and Measurement

The terms and symbols used in the acoustic output tables are defined in the following paragraphs.

ISPTA.3	The derated spatial-peak temporal-average intensity (milliwatts per square centimeter).
ISPPA.3	The derated spatial-peak pulse-average intensity (watts per square centimeter). The value of IPA.3 at the position of global maximum MI (IPA.3@MI) may be reported instead of ISPPA.3 if the global maximum MI is reported.
MI	The Mechanical Index. The value of MI at the position of ISPPA.3, (MI@ISPPA.3) may be reported instead of MI (global maximum value) if ISPPA.3 is $190\text{W}/\text{cm}^2$
Pr.3	The derated peak rarefactional pressure (megapascals) associated with the transmit pattern giving rise to the reported MI value.
WO	The ultrasonic power (milliwatts). For the operating condition giving rise to ISPTA.3, WO is the total time-average power;. For operating conditions subject to reporting under ISPPA.3, WO is the ultrasonic power associated with the transmit pattern giving rise to the value reported under ISPPA.3
fc	The center frequency (MHz). For MI and ISPPA.3, fc is the center frequency associated with the transmit pattern giving rise to the global maximum value of the respective parameter. For ISPTA.3, for combined modes involving beam types of unequal center frequency, fc is defined as the overall ranges of center frequencies of the respective transmit patterns.
ZSP	The axial distance at which the reported parameter is measured (centimeters).
x-6,y-6	are respectively the in-plane (azimuth) and out-of-plane (elevation) -6 dimensions in the x-y plane where ZSP is found (centimeters).
PD	The pulse duration (microseconds) associated with the transmit pattern giving rise to the reported value of the respective parameter.
PRF	The pulse repetition frequency (Hz) associated with the transmit pattern giving rise to the reported value of the respective parameter.

EBD	The entrance beam dimensions for the azimuth and elevation planes (centimeters).
EDS	The entrance dimensions of the scan for the azimuth and elevation planes (centimeters).

2.5.1.16 Acoustic Measurement Precision and Uncertainty

The Acoustic Measurement Precision and Acoustic Measurement Uncertainty are described below

Quantity	Precision	Total Uncertainty
PII.3 (derated pulse intensity integral)	3.2 %	+21 % to - 24 %
Wo (acoustic power)	6.2 %	+/- 19 %
Pr.3 (derated rarefaction pressure)	5.4 %	+/- 15 %
Fc (center frequency)	< 1 %	+/- 4.5 %

1) Systematic Uncertainties

For the pulse intensity integral, derated rarefaction pressure Pr.3, center frequency and pulse duration, the analysis includes considerations of the effects on accuracy of:

Hydrophone calibration drift or errors.

Hydrophone / Amp frequency response.

Spatial averaging.

Alignment errors.

Voltage measurement accuracy, including.

- Oscilloscope vertical accuracy.
- Oscilloscope offset accuracy.
- Oscilloscope clock accuracy.
- Oscilloscope Digitization rates.
- Noise.

The systematic uncertainties Acoustic power measurements using a Radiation Force are measured through the use of calibrated NIST acoustic power sources. We also refer to a September 1993 analysis done by a working group of the IEC technical committee 87 and prepared by K. Beissner, as a first supplement to IEC publication 1161.

The document includes analysis and discussion of the sources of error / measurement effects due to:

- Balance system calibration.
- Absorbing (or reflecting) target suspension mechanisms.
- Linearity of the balance system.
- Extrapolation to the moment of switching the ultrasonic transducer (compensation for

ringing and thermal drift).

- Target imperfections.
- Absorbing (reflecting) target geometry and finite target size.
- Target misalignment.
- Ultrasonic transducer misalignment.
- Water temperature.
- Ultrasonic attenuation and acoustic streaming.
- Coupling or shielding foil properties.
- Plane-wave assumption.
- Environmental influences.
- Excitation voltage measurement.
- Ultrasonic transducer temperature.
- Effects due to nonlinear propagation and saturation loss.

The overall findings of the analysis give a rough Acoustic Power accuracy figure of $\pm 10\%$ for the frequency range of 1 – 10 MHz.

2.6 Environmental Protection

CAUTION



- The console and peripherals could be sent back to manufacturers for recycling or proper disposal after their useful lives.
- Disposal of waste shall be disposed in accordance with national laws.
- The waste sheaths are to be disposed of safely and national regulations must be observed.



Waste Electrical and Electronic Equipment

NOTE This symbol is applied in the European Union and other European countries

This symbol on the product indicates that this product shall not be treated as household waste. Instead it shall be handed over to the applicable collection point for the recycling of electrical and electronic equipment. By ensuring this product is disposed of correctly, you will help prevent potential negative consequences for the environment and human health, which could otherwise be caused by inappropriate waste handling of this product. The recycling of materials will help to conserve natural resources. For more detailed information about recycling of this product, please contact your local city office, your electrical and electronic waste disposal service or the shop where you purchased the product.

3 Installing the Product

3.1 Overview

Chapter 3 contains the information necessary to plan the installation of SONOACE X6 and install it.

This chapter describes the requirements for the transportation and installation environment for the product, so that the product is installed in the best condition. Also included are product installation and set up procedures and electrical security check procedures. In addition, procedures for connecting probes and external equipment are included.

Contents Installing the Product

3.1	Overview	3-1
3.2	Transportation	3-3
3.2.1	Precautions for Transportation	3-3
3.2.2	Temperature and Humidity	3-3
3.2.3	Transportation of the Product	3-4
3.3	Unpacking	3-5
3.3.1	Unpacking the Box	3-5
3.3.2	Checking Package Contents	3-6
3.4	Precautions for Installation	3-7
3.4.1	Precautions	3-7
3.4.2	Installation Location	3-8
3.5	Installation Procedure	3-9
3.5.1	Installation Safety	3-9
3.5.2	Connecting the Power Cord	3-10
3.5.3	Connecting the Network Cable	3-11
3.5.4	Connecting the Foot switch	3-11
3.5.5	Connecting the Probe	3-12
3.6	Starting the Product	3-13
3.7	Shutting down the Product	3-15
3.7.1	Power Switch	3-15
3.7.2	Cut-off Switch	3-15

3.8	Connecting the Peripherals	3-16
3.8.1	BW Printer	3-16
3.8.2	Color Printer	3-17
3.8.3	Line Printer	3-18
3.8.4	VCR	3-18
3.8.5	USB Storage Device	3-19
3.9	System Setting	3-20
3.9.1	General System Setup	3-20
3.9.2	Display Setup	3-22
3.9.3	Misc	3-24
3.9.4	Peripherals Setup	3-25
3.9.5	Information	3-26
3.9.6	DICOM Setup (Option)	3-27
3.9.7	Option Setup	3-34

3.2 Transportation

SONOACE X6 is a sensitive piece of electronic medical equipment. Take care when moving it.

3.2.1 Precautions for Transportation

- 1) The box packaging is designed to diminish the effects of any impact to the product. However, take care not to subject the product to any external impact.
- 2) If the box is subjected to an impact or is dropped, the shock sensor as illustrated below will indicate that a shock has occurred. In this case, contact the customer service department of MEDISON Co., Ltd. or an authorized engineer immediately.

NOTE Direct impact to the shock sensor may cause an error.



[Figure 3-1] Shock Sensor to identify damage during transportation

3.2.2 Temperature and Humidity

The following [Table 3-1], “Temperature and Humidity Requirements” shows the required temperature and humidity for the transportation, care and operation of the product.

Type	Temperature [°C]	Humidity [%]
Transportation & Care	-25 ~ 60	20 ~ 90
Operation	10 ~ 35	30 ~ 75

[Table 3-1] Temperature and Humidity Requirements

3.2.3 Transportation of the Product

- 1) Moving the product package by forklift, or with not less than 4 persons, is recommended.
- 2) The product should be delivered to the end user without removing the packaging, to avoid external shocks to the product.

3.3 Unpacking

3.3.1 Unpacking the Box.

- 1) Remove the box strap.
- 2) Lift the top side of the box up and remove it
- 3) Lift the box body up and remove it.
- 4) Remove the protective plastic packaging.
- 5) Take the probe and accessory boxes out and put them in a safe place.
- 6) Fix the panel for carrying the product.
- 7) Unlock the wheel.
- 8) Hold the rear handle and move the product to its installation location, pulling it gently by the handle.
- 9) It is recommended to use two persons when wheeling the product.

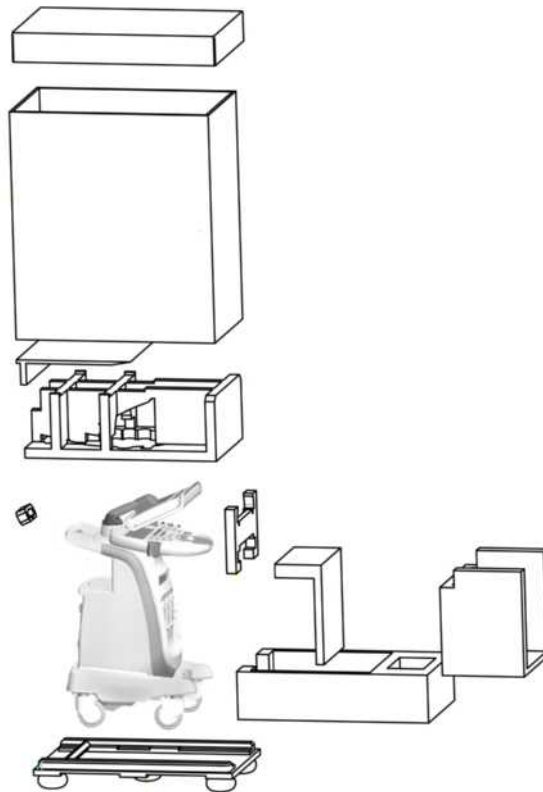

[Figure 3-2] Unpacking the Box

CAUTION When moving the product up a steep incline or over a long distance, there is a danger of injury.



3.3.2 Checking Package Contents

Unpack the product's packaging and check the package contents.

If there are any missing parts, contact your dealer.

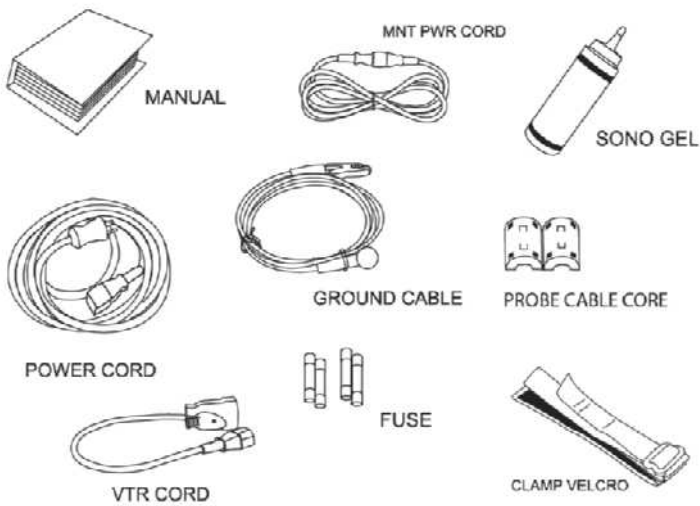

[Figure 3-3] Contents of SONOACE X6 Package

3.4 Precautions for Installation

3.4.1 Precautions

Please follow the precautions below.

- 1) Avoid installing the product where water may get into it.
- 2) Avoid installing the product in direct sunlight.
- 3) Avoid installing the product in places where there are high temperature fluctuations.
- 4) Temperatures of 10°C ~ 35°C and a humidity of 30% ~ 75% are required for normal operation..
- 5) Avoid installing the product near a heater.
- 6) Avoid installing the product in a dusty location, or where there is a lack of ventilation.
- 7) Avoid installing the product in a location subject to vibration.
- 8) Avoid installing the product where there are chemicals or gas.

CAUTION



If you use the product near a generator, X-Ray equipment, or a broadcasting transmission cable, the screen may not work normally due to interference.

In addition, sharing the same wall outlet with other electric equipment may cause noise.

3.4.2 Installation Location

- 1) The width of the door must be at least 60cm for the product to pass through.
- 2) The distance between the wall and the product must be at least 30cm.
- 3) The wall outlet, grounding terminal and LAN connector (Ethernet Connector or LAN Connector) should be within 1m of the product.
- 4) The illumination should be capable of being brightened or dimmed.
- 5) There must be sufficient ventilation in the room.

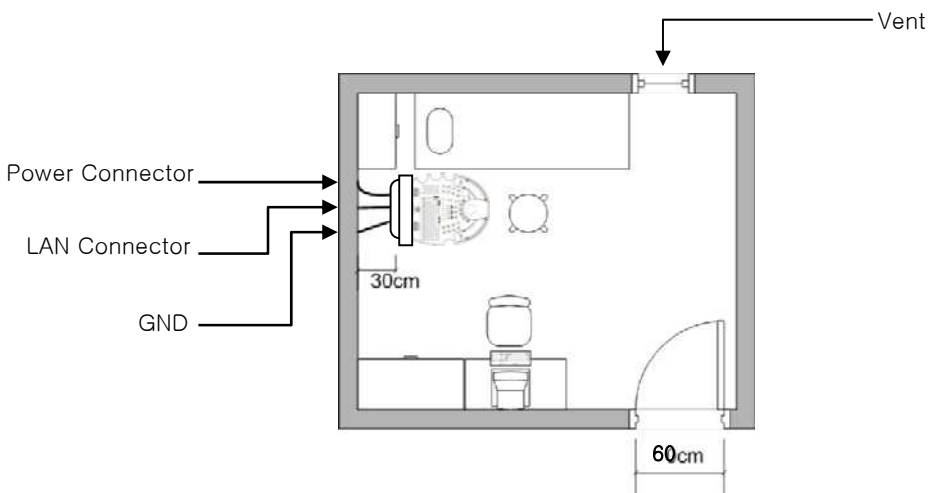

[Figure 3-4] Installation location

3.5 Installation Procedure

3.5.1 Installation Safety



If you use the product near a generator, X-Ray equipment, or a broadcasting transmission cable, the screen may not work normally due to interference.

In addition, sharing the same wall outlet with other electric equipment may cause noise.

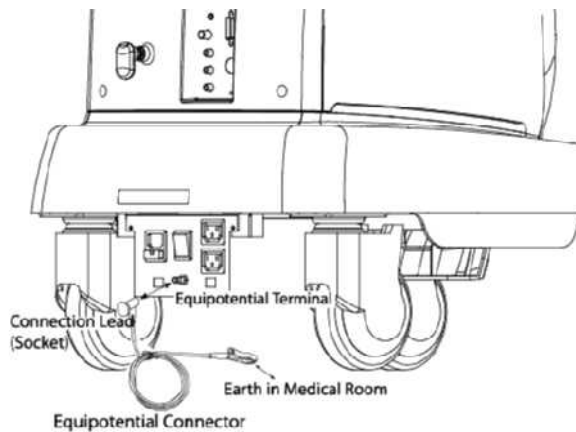

[Figure 3-5] Equal Electric Potential Terminal (Ground) Connection

CAUTION



- When moving or storing the product for a long time, you should check the temperature and humidity of the environment.
- Turn the power on after referring to the information in the following [Table 3-2] “Product Operation Temperature”.
- Sudden temperature change causes dew and may generate problems in the product.

Temperature	-20	-15	-10	-5	0	5	10 ~ 40	45	50	55	60
Time to Wait	16	10	8	6	4	2	Immediate	2	4	6	10

[Table 3-2] Product Operation Temperature

3.5.2 Connecting the Power Cord

Make sure to check the output voltage of the wall outlet in the installation location. For the stable operation of SONOACE X6, use it within the voltage range specified in the following [Table 3-3] “Product Voltage”.

Connect the power cord to the power port on the rear panel of SONOACE X6.

NOTE The product and the power cord may be connected before shipping.

Connect the Power Cord



[Figure 3-6] Product Power

Voltage	Allowable Voltage Range	Frequency
110VAC	+/- 10%	50~60Hz
220VAC	+/- 10%	50~60Hz

[Table 3-3] Product Voltage

3.5.3 Connecting the Network Cable

Connect the network cable to the LAN port on the rear panel of SONOACE X6.

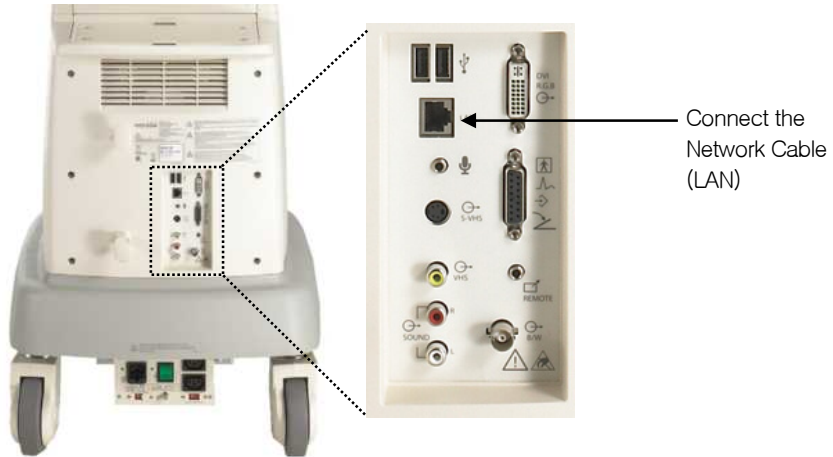

[Figure 3-7] Network Cable Connection

3.5.4 Connecting the Foot Switch

Connect the foot switch to the port on the rear panel of SONOACE X6.

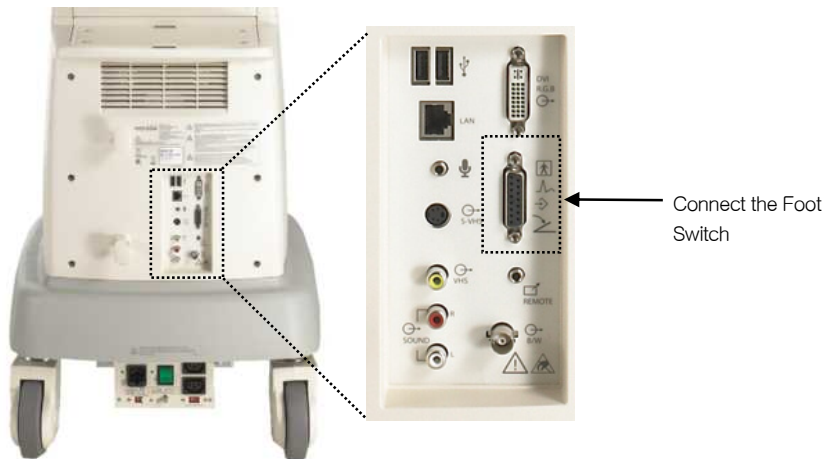

[Figure 3-8] Foot Switch Cable Connection

3.5.5 Connecting the Probe

SONOACE X6 provides 3 probe connections on its front panel.

The probe connections are numbered 1, 2 and 3 from the left. SONOACE X6 can be connected to any of these probe connections.

Place a probe in the probe holder and connect it up.

CAUTION



- Do not connect with excessive force, to prevent damage to the probe connection pin and the connector PCB.
- Be sure to connect or disconnect probes when the power is off to ensure the safety of the system and the probes.

- 1) Connect probes when the probe handle is unlocked (when the knob is turned counterclockwise).
- 2) Connect probes with the probe cable pointing downwards.
- 3) Turn the probe handle clockwise until it is fixed at the opposite direction of the cable.



Unlocked State



Locked State

[Figure 3–9] Probe Connections

CAUTION



Although you can connect a probe when the power is on, do not connect or disconnect a probe during the booting sequence of the product.

3.6 Starting the Product

- 1) Check again if the power capacity is compliant with SONOACE X6 and connect the power cord to the wall outlet.
- 2) Check if the SONOACE X6 power cord is properly connected and switch on the cut-off switch for the AC power. [Figure 3-10]

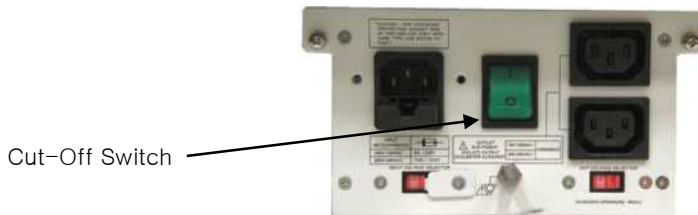

[Figure 3-10] AC Power

CAUTION



- The product should be turned on about 10 seconds after the AC power switch at the back of the product is turned on.
- During booting the system, do not press any key of the alphanumeric keyboard. It may cause malfunction.
- If you turn on the power after turning off forcibly, the system can turn on and off momentary. It is one of the character of PC main board, not system error.

- 3) To start SONOACE X6, press the On/Off switch at the center of the control panel (keyboard).



[Figure 3-11] Power Switch

- ① The booting sequence is displayed on the LCD monitor. As the SONOACE X6 logo disappears and loading bar appear.
- ② The loading bar fills with color. This represents data being copied to the Front End and Back End of system by the PC software.

- ③ When software data copying is completed, the ultrasound picture appears and the system becomes ready. The booting sequence of the product takes approximately 1 minute.

3.7 Shutting down the Product

You can shut down SONOACE X6 by either turning the system off or switching off the cut-off switch.

3.7.1 Power Switch

- 1) Turning the system off: Press the On/Off switch at the right side of the control panel (keyboard). Press and hold down the button for 2 seconds to turn the product On

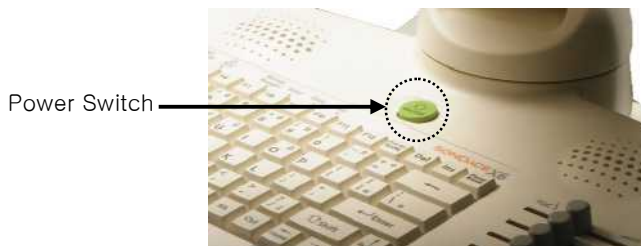

[Figure 3-12] Power Switch

CAUTION



- Pressing the On/Off button over five seconds turn off the power forcibly. It can cause hard disk damage.
- If this problem repeats, contact the customer service department of MEDISON Co., Ltd. or an authorized engineer.

3.7.2 Cut-off Switch

- 1) Switching off the cut-off switch : You can cut off the power by switching off the cut-off switch after turning the system off.
- 2) Cut the power off in the event of storing the product for a long period of time, or when repairing the product.



[Figure 3-13] AC Power

3.8 Connecting the Peripherals

SONOACE X6 provides various connectors so that various external devices can be connected. Peripherals can include a mono printer, color printer, line printer, USB storage device, and VCR.

These are peripheral devices that can be connected for use when needed and are connected via the USB port located at the rear panel.

CAUTION



When using a peripheral device from a USB port, always turn the power off before connecting/disconnecting the device. Connection / disconnection of USB devices during power-on may lead to malfunction of the system and USB devices.

NOTE

- USB ports are located both on the front panel and the rear panel of the console.
- We recommend that you connect USB storage devices (MO drive, flash memory media, etc.) to the ports on the front panel and other USB peripheral devices to the rear panel for added convenience.

3.8.1 BW Printer

Connect a mono printer to either the BNC or USB interface connector. the following products are recommended :

Mitsubishi P91W, Mitsubishi P93W, SONY UP-897MD

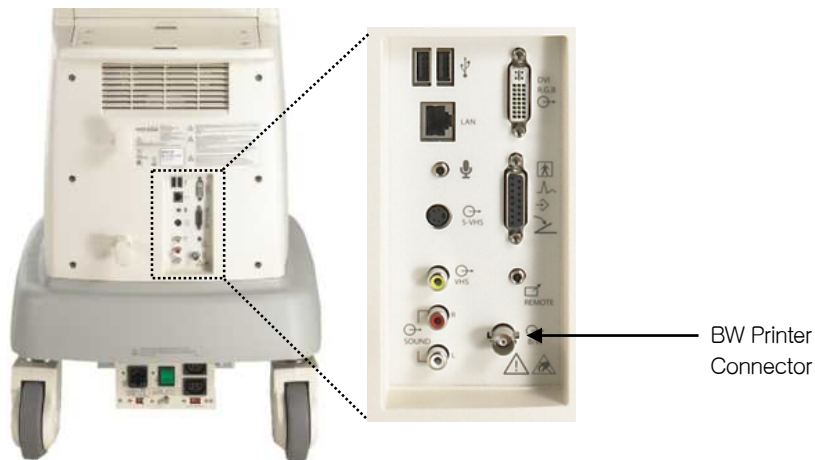

[Figure 3-14] BW Printer Connector

3.8.2 Color Printer

Connect a color printer to either the VHS, S-VHS or USB interface connector. the following products are recommended :

SONY UP-20, SONY UP-21MD

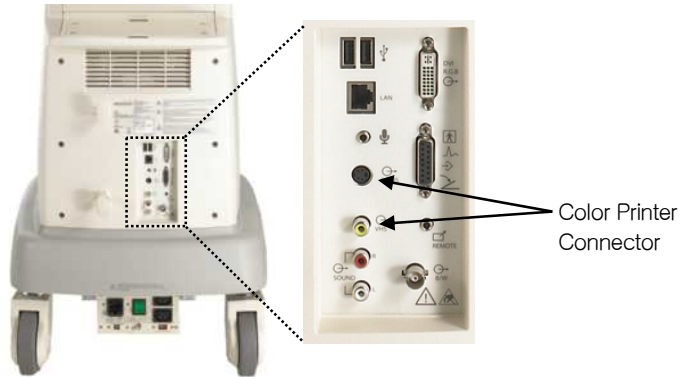

[Figure 3-15] Color Printer Connector

3.8.3 Line Printer

Connect a line printer to either the USB port.

'Line printer' means an Inkjet Printer or a Laser Printer. following products are recommended :

HP DeskJet 5650, HP DeskJet 5940, HP DeskJet 6540, HP DeskJet 6940,
HP DeskJet 6980, HP LaserJet 1320, HP LaserJet 2420, HP LaserJet P2015,
HP Color LaserJet 3600, HP OfficeJet J5780, HP OfficeJetProK550

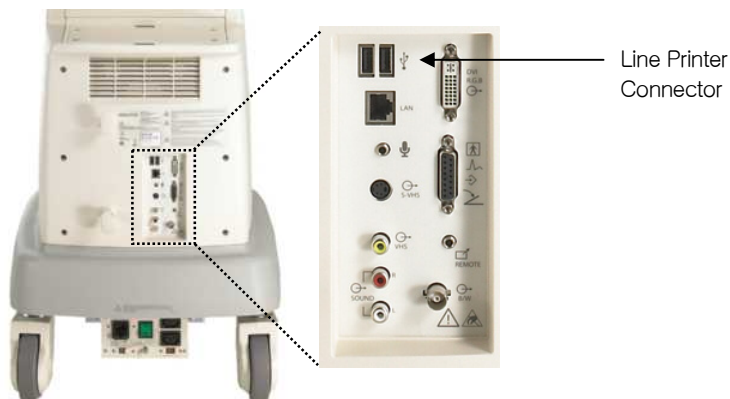

[Figure 3-16] Line Printer Connector

CAUTION



- You must install a Linux or above (English) compatible printer and driver. Contact MEDISON customer service department for inquiries about printer driver installation.
- When connecting the printer, ensure that the printer is configured under Linux or system setup and has been chosen as the default printer.
- Please check the port used in printer before connecting. Printers should be connected to the Printer port while the USB printer connected to the USB port.

3.8.4 VCR

Connect a VCR to either the connector of Image signal and voice signal.

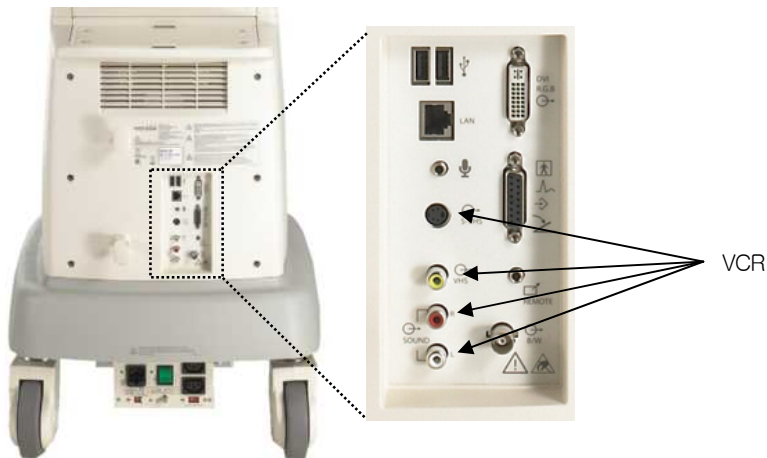

[Figure 3-17] VCR Connector

3.8.5 USB Storage Device

You can use USB port on both of the front and rear side of the system to connect a USB storage device. the following products are recommended :

- ① USB Magnetic Optical (MO) Disk Drive : Fujitsu DynaMO1300U2B or later version
- ② USB RS-232C serial cable : USB to Serial (RS-232C) Converter with FTDI Chipset (FTDI FT232BM Compatible)
- ③ USB Flash Memory media : Imation iFLASH USB2.01GB, Imation USB Swing Blue 1G

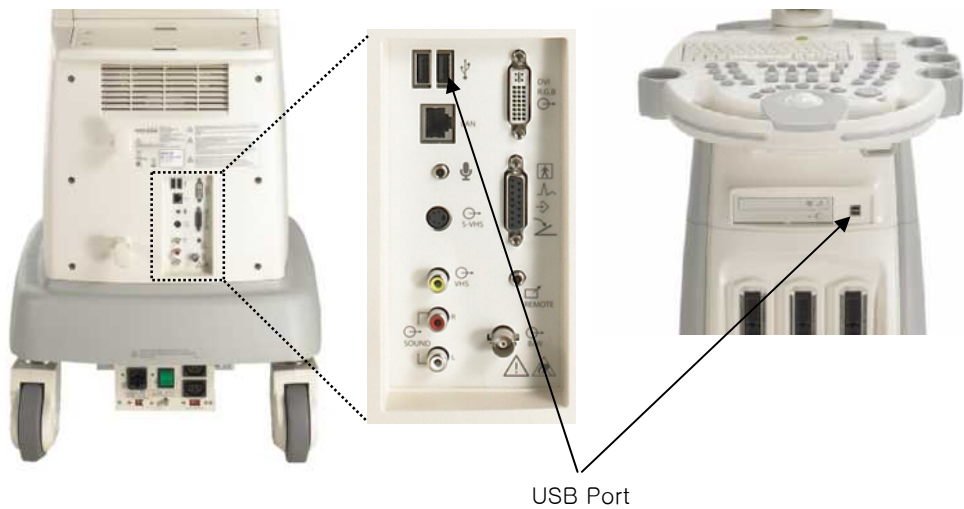

[Figure 3-18] USB Port

CAUTION

The USB MO Drive should not be used with other USB storage devices simultaneously.

NOTE

If you use the USB 1.1 flash memory, the system cannot recognize it. In the case of this, delete the flash memory from the console and quip again.

3.9 System Settings

This mode is used for system settings. It does not affect image output. The setup may be modified depending on specific needs or preferences.

- 1) Press the **[F8] Setup** button on the keyboard. *Setup* window is appeared.
- 2) Select **System** in the Setup menu.
- 3) Set the specific system values according to each item on the screen.
- 4) Press **Ok** to finish the setup. To close the screen, press **Cancel** or **X**.

3.9.1 General System Setup

Select the **General** tab in the *Setting* screen. You can specify general settings such as title settings.

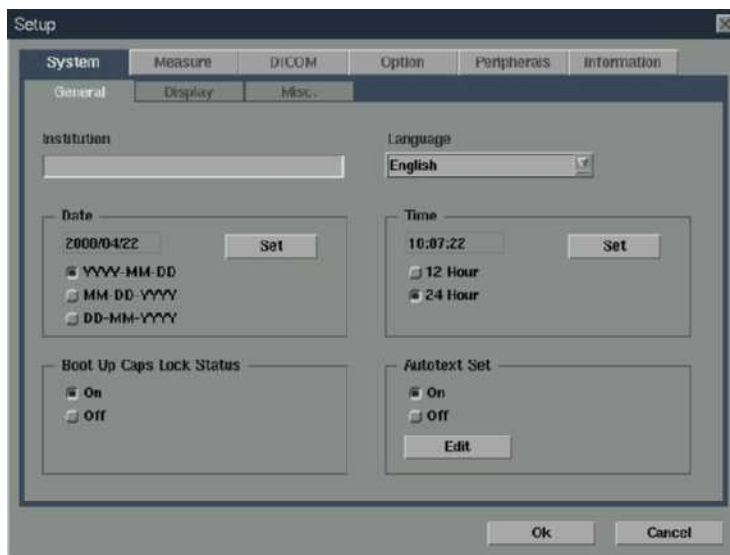

[Figure 3-19] General System Setup

3.9.1.1 Institution

Enter the name of the hospital/institution

3.9.1.2 Language

This sets the language to be used. English, Deutsch, Français, Italiano, Español, Russian, and Simplified Chinese are available. To display the screen in the selected language, reboot the system after completing setup.

The input setup of key button is automatically updated

3.9.1.3 Date

Set the date and its format

3.9.1.4 Time

Set the time and its format

※ Tip! How to set the date and time

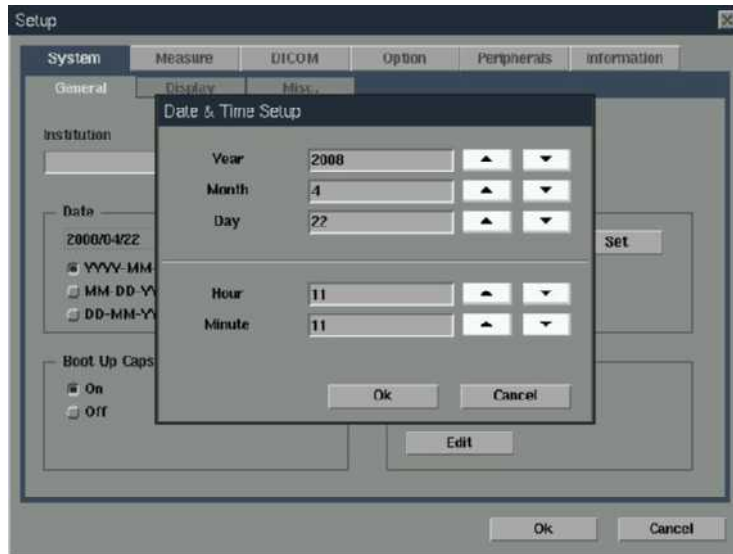

[Figure 3-20] System Setup – Date/Time

- ① Click **Set** in the **Title** tab of System menu.
- ② Set the Date/Time using the **Trackball** and **Set** button.
- ③ After finishing setup correctly, click **Ok**. To cancel setup, click **Cancel**.

3.9.1.5 Boot Up Caps Lock Status

This menu sets the initial status of Caps Lock after system boot-up. Its default value is 'Off'. This Caps Lock enables capital letter entry without the need to press the **Shift** key.

3.9.1.6 Autotext Set

Select **Autotext Set** to use the Autotext text function. Its default value is 'Off'.

Using the Autotext text function allows fast and easy input of text statements. For example, to enter the text 'Tumor', you only need to enter 'Tu' and the system will search the word from the abbreviation list and automatically enter the word 'Tumor'.

※ How to edit the Autotext Set

Press the **Edit** button on the screen. The Autotext Table Edit table window will be appeared. To add a new abbreviation, click **New**, and to completely delete an existing abbreviation, click the entry to be deleted and then click **Delete**.

'Delay(msec)' sets seconds to input the full word after enter the abbreviation. The unit value is msec, and 1000msec is 1second.

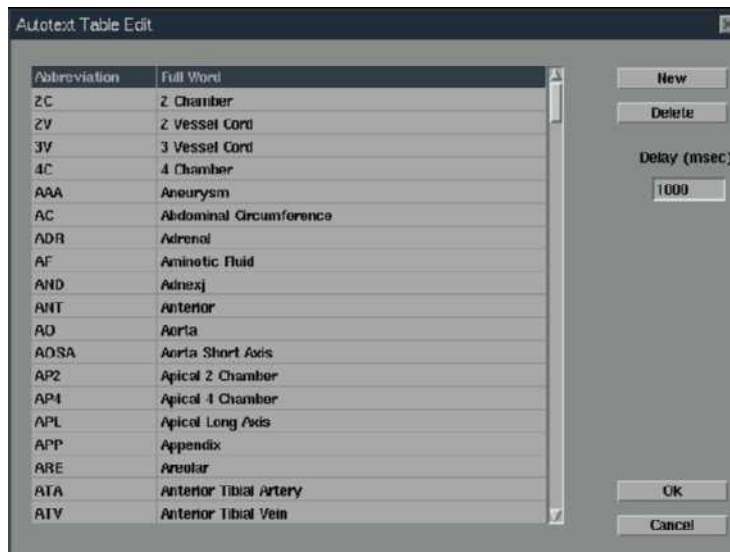

[Figure 3-21] Autotext Set Edit

3.9.2 Display

To set the information about images and related data, select the **Display** tab in the **System** menu.

3.9.2.1 Auto Freeze

After the preset time span (Minute) of inactivity, the scan mode is automatically frozen.

3.9.2.2 Screen Saver

After the preset time span (Minute) of inactivity, the screen saver is automatically started

3.9.2.3 Post Map

This sets the display of the Post Map in the Feedback section at the bottom of the screen

3.9.2.4 TGC Line

This sets whether or not the TGC line is displayed. If 'Off' is selected, the TGC Line is not shown. If 'Off after 3 seconds' is selected, the TGC value appears when a TGC value is adjusted, but disappears after 3 seconds. If 'On' is selected, the TGC Line is always shown

3.9.2.5 TI(Thermal Index) Display

The system sets TI values automatically. However, this menu allows the user to choose manually from one of the three TI parameters as desired: Default, TIs or TIb.

3.9.2.6 HPRF Set

Enable or disable High Pulse Repetition Frequency (HPRF) supported in the PW Spectral Doppler mode. If it is set to 'On,' HPRF is supported by default.

3.9.2.7 Bodymarker After Freeze

Determine whether the system will automatically switch to the Body Marker mode when the **Freeze** button is pressed. If it is set to 'On,' a Body Marker appears when the **Freeze** button is pressed during scanning. If it is set to 'Off,' a Body Marker appear only when **BodyMarker** is pressed during scanning.

3.9.2.8 2D Image Size

The Image size can be set to 100%, 95% or 90%.

3.9.2.9 Simultaneous Mode

This menu determines whether or not simultaneous mode is enabled in PW Spectral Doppler Mode.

- ① 'Off': Select this if you do not wish use simultaneous mode.
- ② 'Allow 2D/PW': Select this if you wish to use simultaneous mode in 2D/ PW mode.

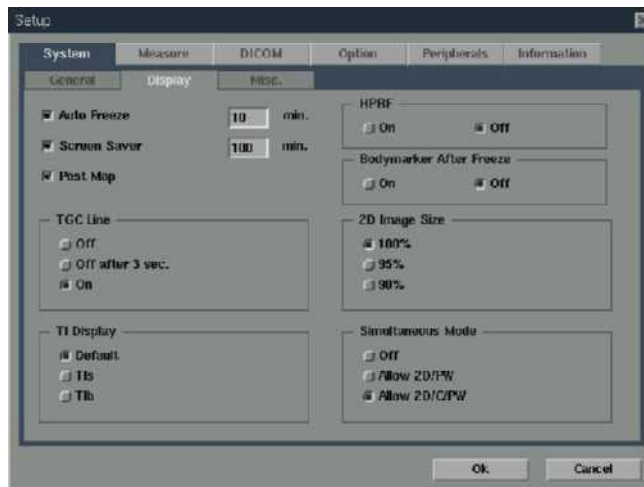

[Figure 3-22] Setup-Display

3.9.3 Misc

Select the **Misc.** tab in the **System** menu.

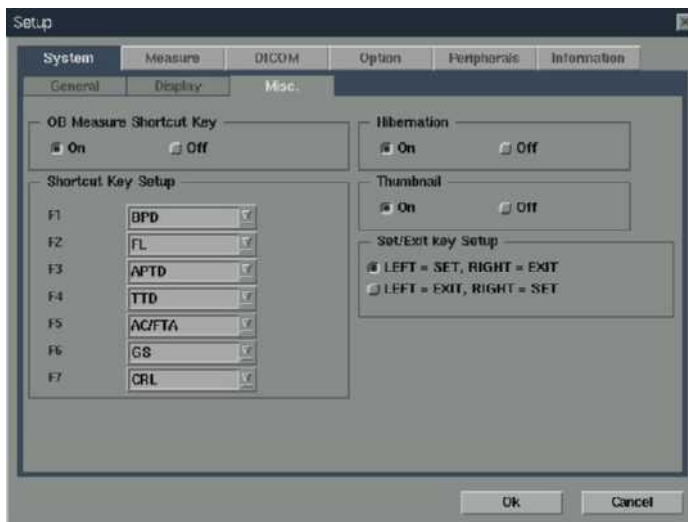

[Figure 3-23] Setup-Misc

3.9.3.1 OB Measure Shortcut Key

Assign commonly used obstetrics measurement items to number keys in the alphanumeric keyboard. You can use this feature to start a desired obstetrics measurement instantly while scanning.

3.9.3.2 Hibernation

To booting speed up, set this item as 'On'.

NOTE The system turns off with normal shutdown after 30th booting with 'Hibernation On'. However the system will start with 'Hibernation On' on the next booting.

3.9.3.3 Thumbnail

To use thumbnail list, set this item as 'On'. Thumbnails of saved images are showed up on the right side of the screen.

3.9.3.4 Set/Exit Key Setup

Set the position of the **Set** and **Exit** buttons.

3.9.4 Setting Peripheral Devices

The following describes how to set up the video output type, video input type, printer, foot switch and network. Select the **Peripherals** tab in the Setup menu.

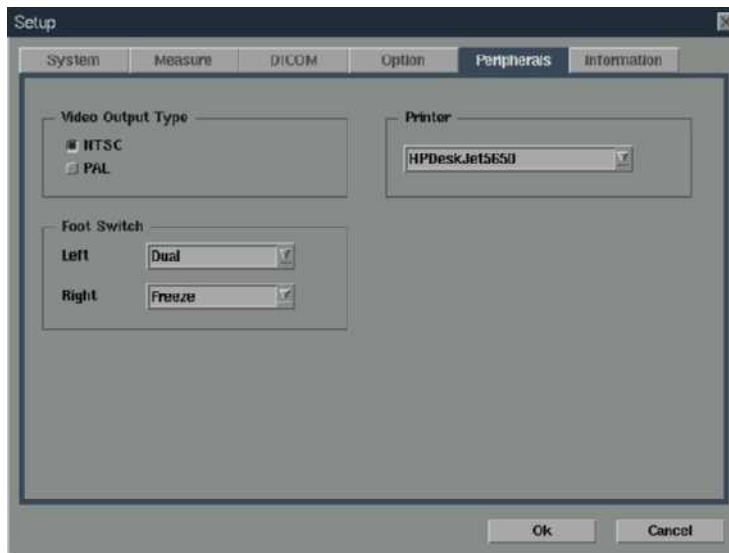

[Figure 3-24] Setup-Peripherals

3.9.4.1 Video Output Type

Set the video input type as VHS or S-VHS.

3.9.4.2 Foot Switch

Assign functions to the left and right pedals of the foot switch. Four options are available: Dual, Store, Freeze and Update.

3.9.4.3 Printer

Select a printer to use. After connecting a USB printer to the USB port of the system, select the printer type on the screen and click **Ok**. The printer can then be used immediately.

The USB printer can only be used to print out Report and SonoView screens.

- HP DeskJet 5650
- HP DeskJet 5940
- HP DeskJet 6540
- HP DeskJet 6940
- HP DeskJet 6980
- HP LaserJet 1320
- HP LaserJet 2420
- HP LaserJet P2015
- HP Color LaserJet 3600
- HP OfficeJet J5780
- HP OfficeJetProK550

3.9.5 Information

The information menu displays information about the system S/W version. Select the **Information** tab in the Setup menu. Press the **Detail Info.** to view more detailed information.

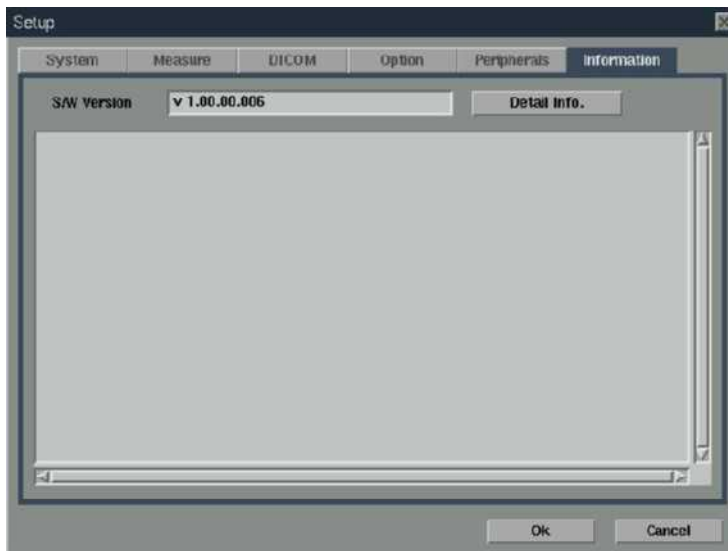

[Figure 3-25] Setup-Information

3.9.6 DICOM Setup (Option)

Select the **DICOM** tab in the Setup menu. This function is used to set up the DICOM server and other DICOM-related functions.

NOTE For more information, please refer to the user manual for the server equipment or the DICOM Conformance Statement.

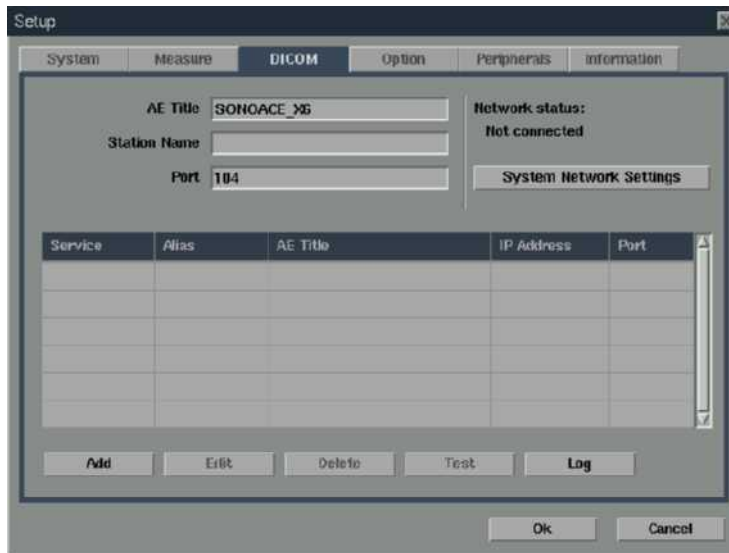

[Figure 3-26] Setup-DICOM

3.9.6.1 Setting DICOM Information

The information on the DICOM server used by the system is displayed.

You can change the information, or add or delete a server. The server information is used to identify DICOM for the system in a network. It is also used to transfer data between other DICOM servers.

NOTE Please consult your network administrator to set **IP Address**, **AE Title** and **Port No.**

1) AE Title

Enter the name of the DICOM AE (Application Entity). The title is used to identify

devices that use DICOM in a network. (Ex. US1, US2, etc.)

2) Station Name

Enter the name of the system. Along with **AE Title**, it is often used to identify the system in the DICOM network. (Ex. SONOACE1, SONOACE2, etc.)

3) Port No.

Enter the port number of the server being used.

4) Network status

Display the current status of the network.

3.9.6.2 Network Setup

To set the network like IP address, press **System Network Settings**. To set the IP value automatically, press 'Using Dynamic IP Configuration'. If you enter the wrong IP address, the network will not run.

To finish the network setup, press the **Apply**. To cancel setup, press the **Close**.

3.9.6.3 Adding DICOM Service

Press **Add** on the screen. The system is switched to a screen where you can enter a DICOM service to add. After adding a service, press **Save** to save the information.

Press **Cancel** to cancel

3.9.6.3.1 Storage Server Information

Select **STORAGE** under **Services**. Configure the Image Storage Service using DICOM.

1) Services

Select the type of service to use via DICOM. The supported DICOM servers are Storage, Print, Worklist, Modality PPS, SC and Storage SR.

2) Alias

Enter the name of the DICOM server.

3) AE Title

Enter the AE title of the DICOM server. Consult your network administrator before specifying this option.

4) Transfer Mode

Select a transfer method:

- ① Batch: Send all saved images when you click the **End Exam** button.
- ② Send As You Go: Send an image whenever you press the **Save** button to save it.
- ③ Manual: Send the specified image in Exam List or SonoView

5) Connect Timeout

Specify how long the system will wait until it receives a response from the DICOM server. You can specify it in seconds.

6) IP Address

Enter the IP address of the server being used. Consult your network administrator before specifying this option.

7) Port

Enter the port number of the server being used. Consult your network administrator before specifying this option

8) Retry Interval

Specify how long the system will wait before it retries when transmission fails. You can specify it in seconds.

9) Maximum Retries

Specify how many times the system will retry when transmission fails.

DICOM Configuration			
Service	<input type="text" value="STORE"/>		
Alias	<input type="text"/>	IP Address	<input type="text"/>
AE Title	<input type="text"/>	Port	<input type="text"/>
Transfer Mode	<input type="text" value="Batch"/>	Retry Interval	<input type="text" value="30"/> s
Connect Timeout	<input type="text" value="10"/> s	Maximum Retries	<input type="text" value="3"/>

[Figure 3-27] DICOM Configuration–Storage

3.9.6.3.2 Print Server Information

Select **PRINT** under **Services**. Configure the Print Service using DICOM

NOTE

- You can configure a printer connected to the DICOM network only.
- Depending on the printer, some of the following functions may not be available. Before configuring a printer service, please refer to the user manual for the printer or the DICOM Conformance Statement.

1) Color

Specify whether to use colors. Select **Grayscale** or **RGB**.

2) Format

Specify the paper layout. Select from 1 x 1, 1 x 2, 2 x 2, 2 x 3, 3 x 3, 3 x 4, 3 x 5, 4 x 4, 4 x 5 and 4 x 6.

3) Orientation

Specify the paper orientation. Select Landscape or Portrait.

4) Magnification

When resizing an image to print, specify the interpolation. Select from Replicate, Bilinear, Cubic and None.

5) Border Density

Specify the border density of an image to print. Select Black or White.

6) Empty Density

Specify the background color of an image to print. Select Black or White.

7) Min Density

Specify the minimum brightness of an image to print. If this option is not specified, the default value is applied.

8) Max Density

Specify the maximum brightness of an image to print. If this option is not specified, the default value is applied.

9) Medium Type

Specify the paper type. Select from Paper, Clear Film, Blue Film, Mammo Clear Film and Mammo Blue Film.

10) Film Size

Specify the paper size. Select from 8 inch x 10 inch, 5 inch x 11 inch, 10 inch x 12 inch, 10 inch x 14 inch, 11 inch x 14 inch, 11 inch x 17 inch, 14 inch x 14 inch, 14 inch x 17 inch, 24cm x 24cm, 24cm x 30cm, A4 and A3.

11) Destination

Specify the paper pathway. Select Magazine or Processor.

12) Smoothing Type

This option is available only when **Magnification** is set to **CUBIC**. Enter a value specified in the DICOM Conformance Statement for the printer.

13) Priority

Specify a priority for the print command. Select from High, Med and Low.

14) Copies

Enter the number of copies between 1 and 99.

15) Configuration Info

Specify the unique value for a printer. Please refer to the DICOM Conformance Statement for the printer.

Printer Setup			
Color	GRAYSCALE	Medium Type	PAPER
Format	2X3	Film Size	8INX10IN
Orientation	PORTRAIT	Destination	MAGAZINE
Magnification	REPLICATE	Priority	HIGH
Border Density	BLACK	Copies(1-99)	1
Empty Density	BLACK	Configuration Information	
Min Density	0		
Max Density	0		

[Figure 3-28] DICOM Configuration-Print

3.9.6.3.3 Worklist Server Information

Select **WORKLIST** under **Services**. Configure the Modality Worklist Service using DICOM.

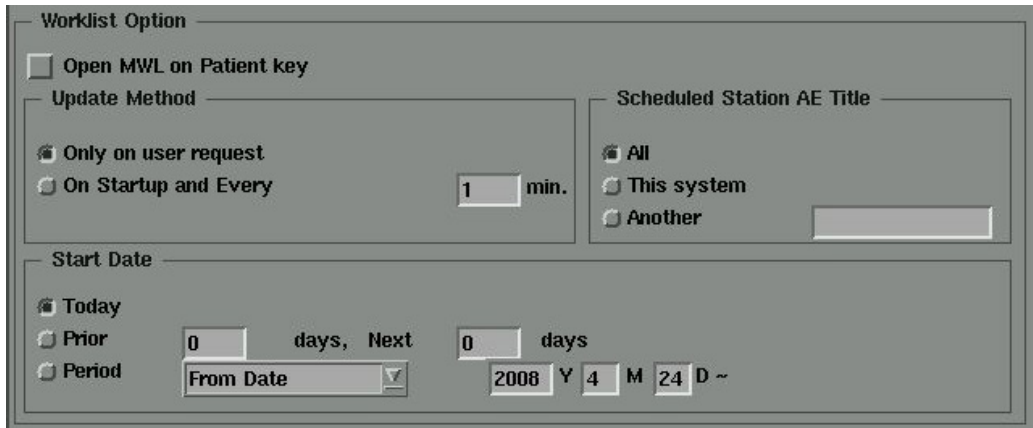

[Figure 3–29] DICOM Configuration–Worklist

1) Open MWL on Patient key

Sets the screen that appears when pressing the **Patient** button on the control panel.

If this function is selected, pressing the **Patient** button opens the Modality Worklist window. If not selected, pressing the **Patient** button opens the Patient Information screen.

2) Update Method

Specify the update method for Worklist.

- ① Only on user Request: Update only when asked by the user.

※ TIP!

To update a worklist, in the **Search** tab on the *Patient Information* screen, select **Worklist** for Search Source and press **Search**.

- ② On Startup and Every : Update automatically at a specified interval after the system boots and Worklist is updated.

3) Scheduled Station AE Title

Specify the range of AE Title to retrieve from the Worklist server in a hospital.

- ① Any : Retrieve the patient list stored in all AE Titles in the server.
- ② This System : Retrieve the patient list specified under the DICOM tab.
- ③ Another : Retrieve the patient list stored in the AE Title specified by the user.

NOTE This option is available only when the Worklist server is enabled.

3) Start Date

Specify the range of dates to search.

- ① Today: Retrieve the patient list for the current date.
- ② Prior_days, Next_days: Retrieve the patient list for n days before and n days after the current date.
- ③ Period: Retrieve the patient list for the period specified by the user.

3.9.6.4 Changing DICOM Information

Select a service and press **Edit** on the screen. The information on the selected service will appear.

After changing the information, press **Save** to save the changes. Press **Cancel** to cancel.

3.9.6.5 Deleting DICOM Service

Select a service and press **Delete** on the screen. A message appears asking whether to delete it. Press **Ok** to delete the selected service. Press **Cancel** to cancel.

3.9.6.6 Testing DICOM Server

Select a service and press **Test** on the screen. The connection with the selected service is tested and the results are shown under the **Ping** and **Verify** items. If the result is Normal, it indicates that the connection is normal.

3.9.6.7 DIOCM Log

Press the **Log** in the setting DICOM window, and the screen will be changed. Set or copy the current DICOM log file.

DICOM log file is the history of all DICOM services performed so far on the product.

Press the **Close** to finish the DICOM log.

1) Log Settings

Set the DICOM Log.

- ① Delete archived log file after: set the number of days to wait before deleting the archived history. After that period, the log file will be deleted. However there is only one log file, it will not be deleted.
- ② Log File Maximum Size: set the maximum size of each history file archived. Set the unit as Kbytes.

2) Explanation

View the log setting.

3) DICOM Log

View, copy, or delete the DICOM log files.

- ① View Selected File: Select the log file from 'Select log files to copy' and press the View selected file.
- ② Copy Selected Files:
Select the log files and set the storage file format on the 'Copy to'.
Set the 'Delete files after copy' whether to delete the log files saved in the hard disk of the system.
Press the Copy selected files.
- ③ Delete Selected Files: Select the log file and press the Delete Selected Files.

3.9.7 Option Setup

The S/W serial No information of the system is shown in this window. You can select/cancel S/W options. A user cannot modify options. Select the **Option** tab in the Setup menu.

If the password you enter is not correct, the options are not activated. If the password is not correct, click **Cancel**.

Options: Shows the types of optional software that can be installed on the product. The following table shows the list of optional software that is available with SONOACE X6 :

- Image filing–SONOVIEW
- DICOM
- Freehand 3D
- Pulse wave Doppler
- Color Doppler
- Cardiac S/W Package

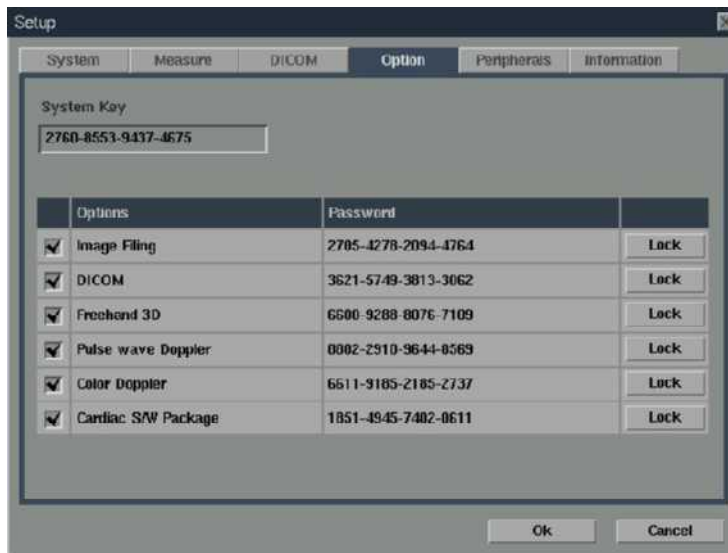

[Figure 3–30] Set-up Options

4 Checking the Product

4.1 Overview

Chapter 4 describes how to check SONOACE X6 and how to check if its major functions and the power supply are working properly.

Contents Checking the Product

4.1	Overview	4-1
4.2	Starting the Product	4-2
4.3	Monitor	4-6
4.3.1	Monitor Display	4-4
4.4	Control Panel	4-6
4.4.1	Power On/Off	4-6
4.4.2	Starting and Finishing Exam	4-6
4.4.3	Selecting Diagnosis mode and Gain Control	4-7
4.4.4	Image Adjustment	4-9
4.4.5	TGC	4-10
4.4.6	Measurement and Annotation	4-10
4.4.7	Trackball and its related control	4-11
4.4.8	SONOVIEW and Report	4-12
4.4.9	Save and Print	4-12
4.4.10	Alphanumeric keyboard	4-13
4.4.11	Flexible Soft Buttons	4-13
4.4.12	Function Buttons	4-14
4.5	Checking the Performance	4-15
4.5.1	Basic Check	4-15
4.5.2	Detail Check	4-16

4.2 Starting the Product

- 1) Check again if the power capacity is compliant with SONOACE X6 and connect the power cord to the wall outlet.
- 2) Check if the SONOACE X6 power cord is properly connected and switch on the cut-off switch for the AC power.

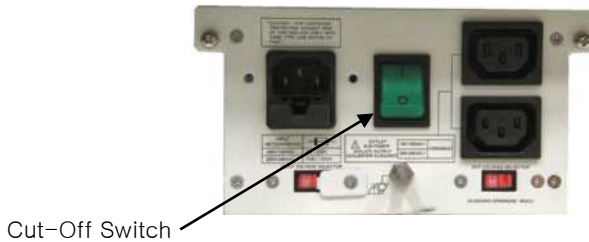

[Figure 4-1] AC Power

CAUTION



- The product should be turned on about 10 seconds after the AC power switch at the back of the product is turned on.
- During booting the system, do not press any key of the alphanumeric keyboard. It may cause malfunction.
- If you turn on the power after turning off forcibly, the system can turn on and off momentary. It is one of the character of PC main board, not system error.

- 3) To start SONOACE X6, press the On/Off switch at the center of the control panel (keyboard).

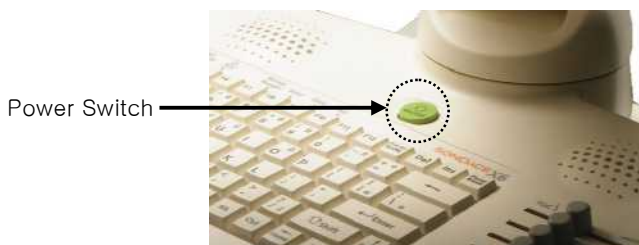

[Figure 4-2] Power Switch

- ① The booting sequence is displayed on the LCD monitor. As the SONOACE X6 logo disappears and loading bar appear.
- ② The loading bar fills with color. This represents data being copied to the Front End and Back End of system by the PC software.

- ③ When software data copying is completed, the ultrasound picture appears and the system becomes ready. The booting sequence of the product takes approximately 1 minute.

4.3 Monitor

The monitor of this system is a color LCD monitor, which displays ultrasound images and additional information. Use the monitor arm to adjust the height or position of the monitor.

4.3.1 Monitor Display

The monitor displays ultrasound images, operation menus and a variety of other information. The screen is divided into six sections: ①Title, ②Menu, ③Image, ④Thumbnail, ⑤Feedback, and ⑥Flexible Soft Menu sections.



[Figure 4-3] Monitor Display

① Title Area

This section displays the Logo, Patient Name, Hospital Name, Application, Frame Rate & Depth, Probe Information, Acoustic Output Information and Date & Time.

② Menu

The menu is divided into 3 kinds: Image adjustment menu, Measurement menu, and Utility menu. Use **Menu** dial-button to select an item from the menu.

③ Image Area

The ultrasound image, image information, annotation, and measurement are

displayed in the image area.

④ Thumbnails Area

Saved images, by pressing the **Save** button on the control panel, are displayed in the thumbnails area.

Click a thumbnail with a pointer to enlarge. When there are more than 9 images, the arrow button on the screen can be used for navigation.

NOTE Refer to 'Chapter 3. Settings' in user manual for detail.

⑤ Feedback Area

This feedback area provides a variety of information necessary for system use e.g. current system status and Body Markers.

⑥ Flexible Soft Menu

The Flexible Soft Menu is displayed on the screen at all times. The items shown on the monitor vary, depending on the status of the system.

4.4 Control Panel

The control panel can be used for controlling the system. It consists of the following five sections:

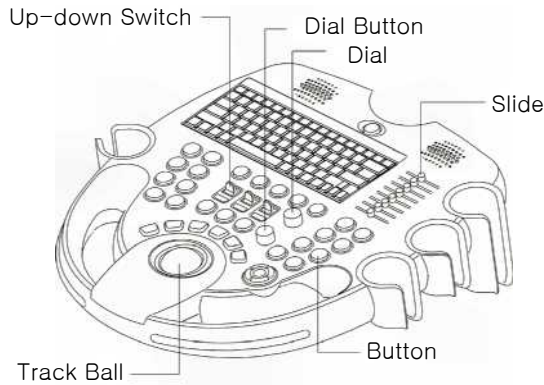

[Figure 4-4] Control Panel

The following are descriptions and instructions for the controls on the control panel. For more information on the buttons with multiple functions, see Chapter 3 and later of user manual

4.4.1 Power On/Off

This is used to Turn the system on/off.

Press the button for about 1 second to turn the product On for use, and press and hold down the button for 2 seconds to turn the product Off after use. Once turned Off, the system needs a 5-second interval before restarting by pressing the button.

4.4.2 Starting and Finishing Exam

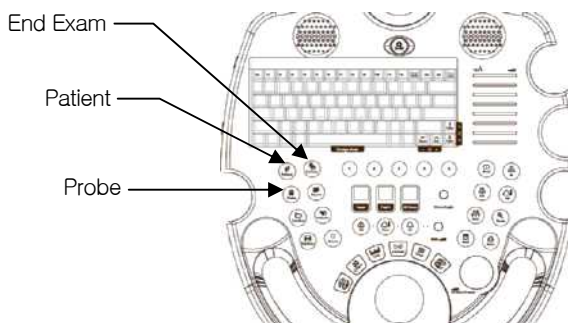

[Figure 4-5] Starting and Finishing Exam

Probe	This is used to change another probe.
Patient	This is used to appear a window for patient selection and information entry.
End Exam	This is used to finish the exam of the currently selected patient and reset the related data.

4.4.3 Selecting Diagnosis mode and Gain Control

NOTE For further information on each Mode, refer to ‘Chapter 4. Diagnosis Modes’ in user manual

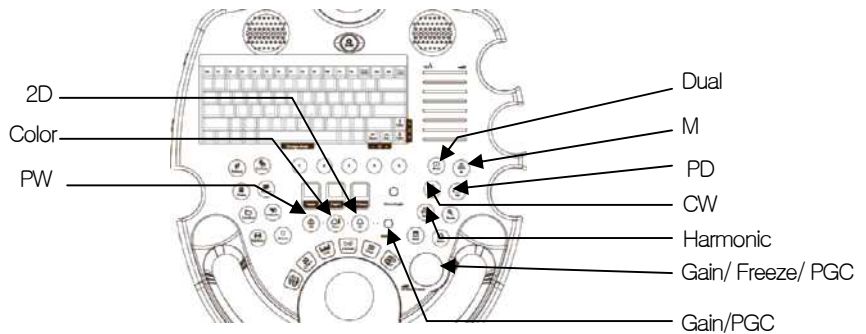

[Figure 4–6] Selecting Diagnosis mode and Gain Control

2D	This is used to view two-dimensional anatomy images in the direction of scanning in real time. Pressing this button while in 2D mode does not turn it off. However, pressing the 2D button will return the system to 2D Mode from other image modes.
M	This is used to turn M Mode on. The M Mode is used to observe the motion patterns of objects occurring over time along a single vector. Press this button again to turn M Mode off.

C	This is used to turn Color Doppler Mode on. Color Doppler Mode shows the pattern of blood flow on 2D image in real time. Press C button again to turn Color Doppler Mode off.
PD	This is used to turn Power Doppler Mode on. Power Doppler Mode displays the color intensity of blood flow within the ROI in the 2D image. Press PD button again to turn Power Doppler Mode off.
PW (Option)	This is used to turn PW Spectral Doppler Mode on. This mode is used to show vascular or cardiac blood flow. 2D Mode can be used simultaneously. Press this button again to turn PW Spectral Doppler Mode off.
CW (Optional)	This is used to turn CW Spectral Doppler Mode on. CW Spectral Doppler Mode gives information on the speed/direction of blood flow in the form of a spectral trace and audio signal.
Dual	This is used to turn Dual Mode on. Dual Mode is used to compare two 2D images. Use the Set button Dual button or Update button to change the activated image in Dual Mode. Press 2D button to turn Dual Mode off.
Harmonic	This is used to turn Harmonic Imaging on. Press this button again to turn the mode off. This button is only activated with the specific probe.
Gain/ Freeze/ PGC	<p>This adjusts 2D Gain, 2D Post Gain or activates the Freeze function.</p> <ul style="list-style-type: none"> ① 2D Gain function – Use the dial in 2D mode to adjust Gain. ② Freeze function – Press the button while scanning to stop the video scanning. LED of this button in frozen state is displayed as blue and Cine, Save, Echo Print, and Measurements are available. Press this button again, LED is displayed as green. ③ 2D PGC(Post Gain Control) function – Changes the post curve in the frozen state to provide effects similar to changing Gain, TGC, DR, etc.
Gain/ PGC	This adjusts Gain or Post Gain.

4.4.4 Image Adjustment

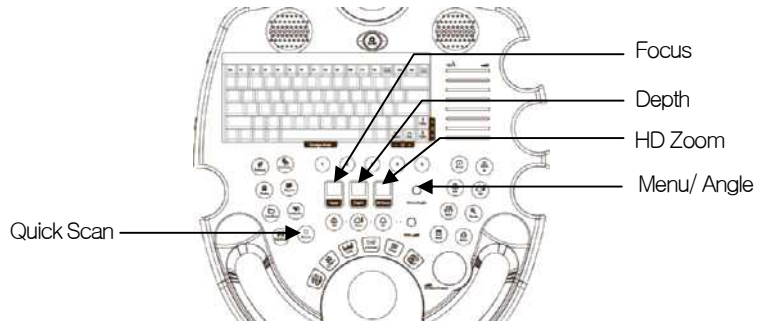

[Figure 4-7] Image Adjustment

Focus	This switch is used to focus on the area of interest. Raise/ lower the switch to raise/lower the focusing point.
Depth	This switch is used to adjust the scanning depth of the image. Raise/ lower the switch to decrease/ increase the scanning depth of an image.
HD Zoom	Raising this switch causes a Zoom box to appear. Modify the size of Zoom box with the Change button and Trackball , and press Set button to apply it to the image. Press Exit button or adjust Depth switch to exit. The position of the magnified area can be adjusted with the Trackball .
Zoom	This is used to perform the Read Zoom function. Adjust the size/position of a 2D image with Change button and the Trackball . Roll the Trackball upwards to view the lower portion of the image, and vice versa. To observe the right/left portion of the image, move the Trackball to the left/right. Press Exit button or Zoom button to exit Zoom mode.
Quick Scan	This is used to adjust Gain, TGC, etc. automatically to optimize Contrast and Brightness. The 'Q' mark is displayed on the top of the image. Press this button again to exit.
Menu/ Angle	Menu function – Press dial button to activate the available menu item of current scan mode. Rotate the dial button to the right/left to move up/down a menu. Angle function – Adjust the angle of sample volume in PW Spectral Doppler Mode. It is also used to adjust the Indicator angle or the Probe angle of Body Marker.

4.4.5 TGC (Time Gain Control)

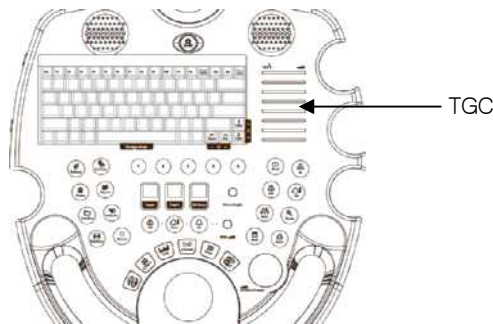

[Figure 4–8] TGC

TGC (Time Gain Control)	8 Eight slides are used to adjust TGC (Time Gain Compensation) values.
----------------------------	--

CAUTION Care should be taken when adjusting TGC values. Too large difference in the gain value settings of two adjacent slides may lead to inaccurate image generation.

4.4.6 Measurement and Annotation

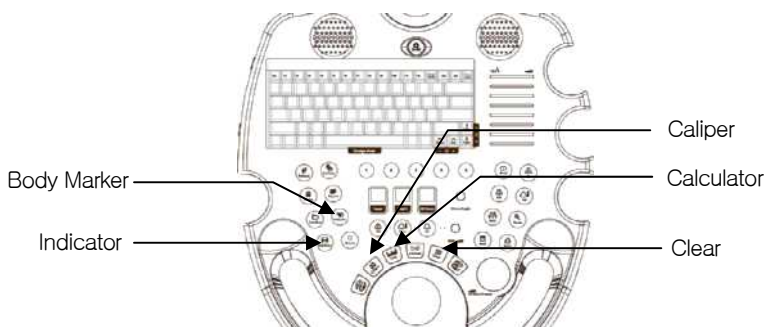

[Figure 4–9] Measurement and Annotation

Caliper	This is used to measure distance, volume, circumference, and area. Press the button repeatedly to cycle through all the available measurement methods.
Calculator	This is used to appear a different measurement menu, depending on the examination subject and diagnosis mode. The examination subject changes each time the button is pressed. Select an appropriate item to perform the measurement.

Indicator	This button is used to appear an arrow marker. It points the parts of the displayed image.
Clear	This button is used to erase the text, Indicator, Body Marker, and measurement data from the displayed image.
Body Marker	This button is used to appear a Body Marker list.

NOTE For more information about Measurement, refer to 'Chapter 5 Measurements and Calculations'. For more information about annotation, refer to 'Chapter 6 Image Managements' in user manual

4.4.7 Trackball and its related control

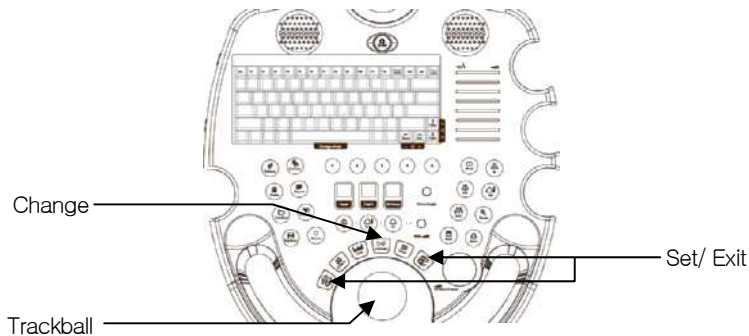

[Figure 4-10] Trackball and its related control

Trackball	This is used to move the cursor on the display and to scroll through CINE images.
Change	This is used to change the current Trackball function. It is used during measurements to alter the position of the last point. It is also used to adjust the position of the text cursor.
Set / Exit	There are two buttons on each side of the Trackball . SET; This is used in conjunction with the Trackball to set a specific item or value. In Spectral Doppler Mode and 3D mode, it is also used as update function. It shows as green color. EXIT; This is used to exit the current mode and return to initial settings. It shows as blue color. The function of each button can be set in Utility > Setup > Peripherals > Key Setup.

4.4.8 SONOVIEW and Report

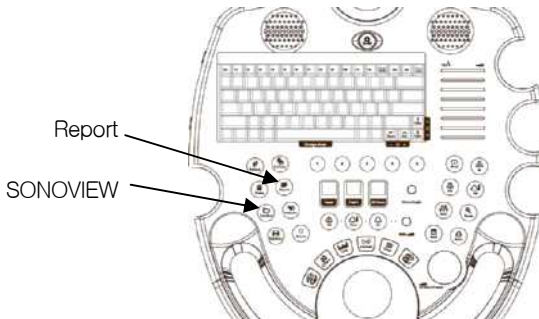

[Figure 4-11] SONOVIEW and Report

SONOVIEW	When this is pressed on the keyboard, SonoView, the Image Filling program, is activated.
Report	When this is pressed on the keyboard, a report program containing measurement results from the current diagnosis mode appears.

NOTE For more information about SonoView, refer to `Chapter 6 Image Managements` and for more information about Report, refer to `Chapter 5 Measurements and Calculations` in user manual

4.4.9 Save and Print

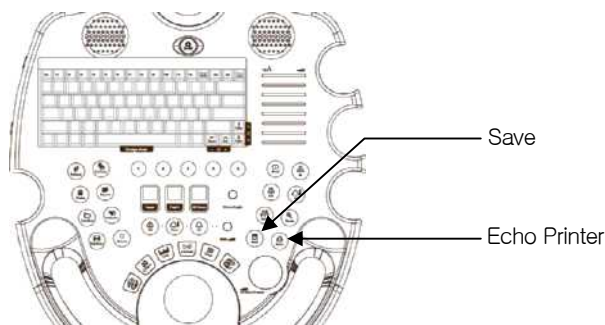

[Figure 4-11] Save and Print

Save	This is used to save a currently displayed image or measurement report in the system database. The user can manage the saved image and report with SonoView.
Echo Print	This is used to print out the current image via an Echo printer.

4.4.10 Alphanumeric keyboard

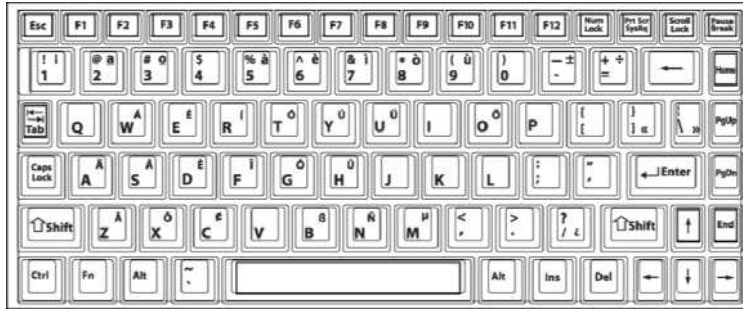

[Figure 4-13] Alphanumeric keyboard

The alphanumeric keyboards are used to type in text. Some function keys are related to measurement.

Z Key	Press this button in HD Zoom mode to hide the Zoom Navigation Box. Press it again to show the box.
-------	---

4.4.11 Flexible Soft Buttons

These buttons activate the corresponding Flexible Soft Menu at the bottom of the screen. (1 ~ 5)

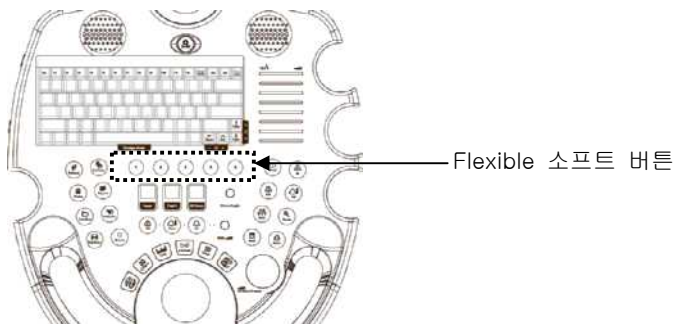

[Figure 4-14] Flexible Soft Buttons

4.4.12 Function Buttons

[F1] Text	This is used to input text.
[F2] M Line	This is used to display M line or hide.
[F3] Biopsy	This is used to start the biopsy.
[F4] Data on / off	This button is used to display information of image on the upper right side of screen or hide.
[F5] 3D	This is used to start 3D Mode.
[F7] Storage Manager	This button is used to appear the Storage Manager window, where saving, transmission, backup and other functions are available.
[F8] Setup	This button is used to appear the Setup window for setting system parameters.
[F9] Utility	This button is used to appear the utility menu.
[F10] Application	This is used to appear a window to select/change probes and applications.

4.5 Checking the Performance

4.5.1 Basic Check

1) Monitor

Check the screen color, focus, dots, residual image, spot, blurring, etc.

Check the screen status when a shock is applied to the monitor and check the signal when you shake the cable.

2) Control Panel and LED Status

Press on control panel key and check if the corresponding character is displayed on the screen.

Check if the Keyboard LED is turned on.

3) Body Mark Key

Check if the Body Mark [Body Mark Key] is properly displayed and if the key works properly.

4) Indicator Key

Check if the trackball works properly by moving it up, down, left and right.

5) Clear Key

Check if TEXT and measurement data is erased properly when this key is pressed.

6) Zoom Operation Examination

Check that the Zoom works properly.

7) SONO VIEW Examination

Save an IMAGE and CINE IMAGE in each mode.

Check if the images are properly saved.

Check if Backup & Restore works properly.

8) Measure

Check if DISTANCE, CALIPER, and CALC works properly.

9) Patient

Enter information in PATIENT and check if the entered contents appear in the report or Sono View.

10) End Exam

Measure for a New Patient and check if the measured data is cleared when End Exam is selected.

11) Probe Key

Check if it works properly when the probe is changed.

4.5.2 Detail Check

1) B Mode

- ① Check if there is any missing line in an image by doing a Knife Test.
- ② Check if the image is displayed properly through Phantom.
- ③ Check if Freeze Cine (Broken Image, Auto run, Auto run Speed and Track ball Cine) and its related functions work properly.
- ④ Check if there is an image brightness change when the Gain is adjusted.
- ⑤ Check if there is an image brightness change when the TGC Gain is adjusted.
- ⑥ Check if the image is flipped horizontally or vertically and left or right when the Left/Right Flip, Up/Down Direction and Rotation keys are pressed.
- ⑦ Check if the image select menus (EE, DR, View Area, Tissue, Frame Rate) work properly.
- ⑧ Check if the frequency (Phantom, Res, Pen, Gen) is normal.
- ⑨ Check if the image changes according to Depth change.
- ⑩ Check if the image changes according to Depth change when the focus is changed.
- ⑪ Check if the image compensation modes (FSI, Harmonic, DMR, SRF, Quick Scan, Spatial Compound Imaging) work properly.

2) Dual Mode

- ① Check if the image is displayed properly through Phantom.
- ② Check if the image is flipped horizontally or vertically and left or right when the Left/Right Flip, Up/Down Direction and Rotation keys are pressed.
- ③ Check if the image select menus (EE, DR, View Area, Tissue, Frame Rate, Sane angle, Power) work properly.
- ④ Check if the frequency (Phantom, Res, Pen, Gen) is normal.
- ⑤ Check if the image changes according to Depth change.
- ⑥ Check if the image changes according to Depth change when the focus is changed.
- ⑦ Check if the left or right image Cine (number of pages, Auto run, Auto run Speed and Track ball Cine) and its related functions work properly.

3) M Mode

- ① Check if the image is displayed properly through Phantom.
- ② Check if the information on M Line is displayed in the Image area.
- ③ Check if there is an image brightness change when the GAIN is adjusted.
- ④ Check if the image select menus (EE, DR, View Area, Tissue, Frame Rate, Sane angle, Power) work properly.
- ⑤ Check if image changes according to Depth change.
- ⑥ Check if image changes according to Depth change when focus is changed.
- ⑦ Check if the speed change and information is correct according to the SPEED conversion step.
- ⑧ Check if an image is reversed when Negative operates.
- ⑨ Check if the Top Down Format and Side by Side Format Image Image are correct when Loop Format is selected.
- ⑩ Check if the Freeze Cine (Broken Image, Auto run, Auto run Speed and Track ball Cine) and its related functions work properly.

4) Color Mode & PD Mode

- ① Check if image is displayed properly through Phantom.
- ② Check if the image select menus (Balance, Sensitivity, Color Mode, Display) work properly.
- ③ Check if image changes according to Depth change.
- ④ Check if the Freeze Cine (Broken Image, Auto run, Auto run Speed and Track ball Cine) and its related functions work properly.
- ⑤ Check if there is image brightness change when the Color Gain is adjusted.
- ⑥ Check if an image is broken or if there is noise (B or C Mode Noise) when ROI Box is moved.
- ⑦ Check if an image is broken or if there is noise (B or C Mode Noise) when ROI Box is resized.
- ⑧ Adjust the Scale up and down and check if the frequency is converted and blood flow speed range is controlled. (Check with directly scan)
- ⑨ Operate the filter and check if small signals are removed by step.
- ⑩ Check if the Color Bar is reserved when the Invert key is pressed.
- ⑪ Move the Baseline up and down and check if the blood flow range moves to + or - part.

5) Doppler Mode

- ① Check if image is displayed properly through Phantom.
- ② Check if the Doppler PRF value changes as the Simultaneous is turned on or off.
- ③ Check if the Doppler spectrum works properly.
- ④ Change the Scale and check the speed range change.
- ⑤ Move the Baseline up and down and check if the blood flow range moves to + or – part.
- ⑥ Operate the filter and check if small signals in the spectrum are removed.
- ⑦ Operate the Invert and check if the Doppler waveform is reversed.
- ⑧ Operate the Angle.
- ⑨ Move the SV or Size and check if it works properly.
- ⑩ Change the Spectrum Type and check if the spectrum video changes.
- ⑪ Check if Sound Volume works properly.
- ⑫ Check if the line when appears when Auto Calc runs is continuous and if the subsequent calculations are automatically done correctly.
- ⑬ Check if the Top Down Format and Side by Side Format Image are correct when LOOP FORMAT is selected.
- ⑭ Check if the CINE/LOOP (Broken Image, Auto run, Auto run Speed and Track ball Cine) and its related functions work properly.

6) 3D Mode

- ④ Check if the loading is normal when Free Hand 3D Scan runs and it is skipped by Freeze, check if the image is fragmented and if there is any noise during the operation.
- ⑤ Check if the ROI 3D, ABC 3D, and Full images are normal.
- ⑥ Check if a 3D image changes according to the selected angle.
- ⑦ Check if the contrast of 3D images changes according to the selected value.
- ⑧ Check if images are displayed properly according to image size changes.
- ⑨ Check if the Display Format Image is normal. (ABC, Volume CT Image)

5 Product Structure

5.1 Overview

Chapter 5 describes the internal structure and operation mechanism of SONOACE X6. This chapter must be read for the product maintenance and upgrade.

SONOACE X6 is high technology ultrasound system.

It not only adopted 15 inch LCD monitor and provides high resolution ultrasound Image, but also provides the premium grade system functions. To improve the processing speed, MEDISON Co., Ltd. developed new interface to connect a latest PC and the ultrasound system with its proprietary technology. The enhancement of processor speed makes the system operations faster and reduces diagnosis time.

SONOACE X6 can use up to 128 Element probes and adopted Digital Beamforming of TX 48 Channels. Ultrasound image is displayed on the LCD through the Front End Part and Back End Part (including PC Part).

The resolution of the LCD monitor is 1024 X 768 pixels and various image formats are provided. The wide view angle of the LCD panel provides convenient work environment for diagnosis. In addition, the monitor controller enables users to control the monitor easily.

The DVD RW drive and USB port are placed on the front panel of the system for easier image backup and software service. Since this system supports various external storage devices such as USB MO, USB Flash Memory and external-type USB HDD, upgrade becomes more easier.

SONOACE X6 consists of the following major components.

- Front End Part : PSA, Front End Board, CW Board
- Back End Part : Back End Board, Rear Board
- User Interface Part : LCD Monitor, Control Panel, Track Ball, Alpha-numeric Keyboard,
- Power Part : DC to DC Power Module, AC to DC Power Module

Contents Product structure

5.1	Overview	5-1
5.2	System Block Diagram	5-3
5.3	Basic Structure of SONOACE X6	5-4
5.3.1	Overview	5-4
5.3.2	Ultrasound System Part	5-5
5.3.3	User Interface Part	5-5
5.3.4	Power Part	5-5
5.4	PSA	5-6
5.5	Front End Board	5-9
5.6	CW Board	5-13
5.7	Back End Board	5-15
5.8	Rear Board	5-22
5.9	Control Panel	5-23
5.10	Power Supply	5-24

5.2 System Block Diagram

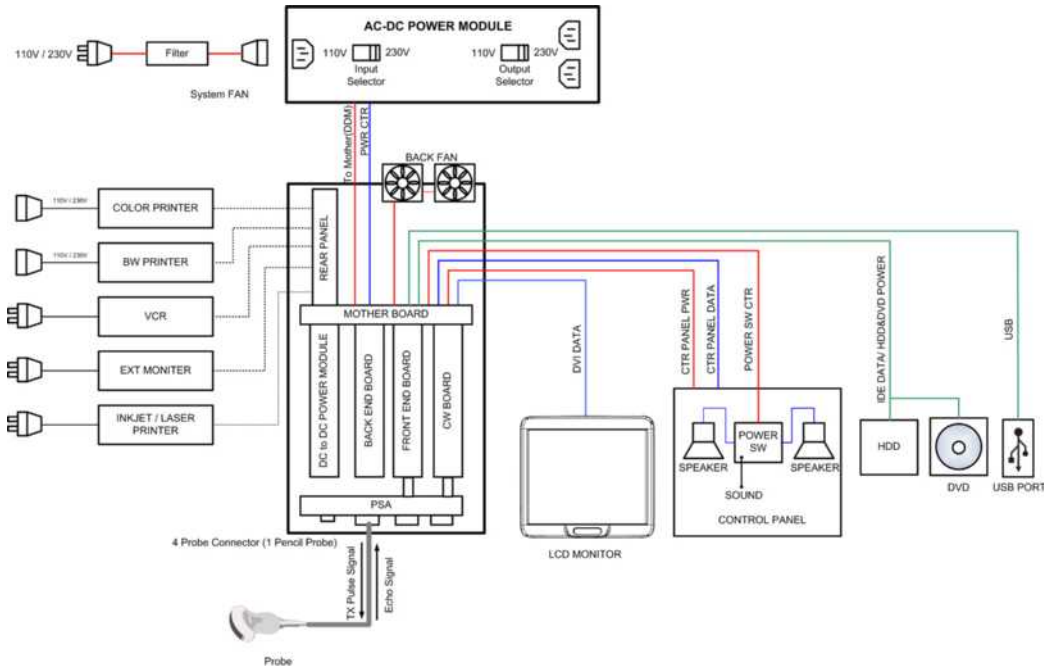

[Figure 5-1] System Block Diagram

5.3 Basic Structure of SONOACE X6

5.3.1 Overview

SONOACE X6 consists of Ultrasound System Part, User Interface Part and Power Part. However, it consists of Front End Part, Back End Part, User Interface Part, and Power Part from the electrical view point.

The following is the description of electrical structure of SONOACE X6.

Front End Part refers to the CW (Continuous Wave) Board, PSA (Probe Select Assembly), and FE (Front End) Board of the Ultrasound System Part. The Front End Part delivers High Voltage Pulser to the probe so that ultrasound is generated, amplifies the returned echo signal and processes Digital Beamforming. The RF signal generated here is delivered to the Back End Part.

Back End Part refers to the BE(Back End) Board and PC of the Ultrasound System Part. The RF signal generated in the FE(Front End) Board is processed to diagnosis image such as BW, Color Doppler, PW Doppler, CW Doppler, and Power Doppler and displayed on the monitor so that users can see it.

User Interface Part refers to the LCD monitor and control panel.

Power Part consists of AC-DC Power Module and DC-DC Power Module. AC-DC Power Module converts AC to DC voltage and supplies power to the DC-DC Power Module. The DC-DC Power Module supplies voltage to the boards of the Ultrasound System Part.

5.3.2 Ultrasound System Part

The major function implements the ultrasound data before the prior step of the Scan Converter.

It plays the roles of the Front End Part and Back End Part (including some).

It recognizes probes and delivers system and application information depending on the user environment to each board. Based on the information, TX Focusing and RX Focusing are done. When high-voltage Pulser is delivered to probe along through the TX Focusing, ultrasound is generated and the echo signal returned from human body is amplified by the amplifier circuit and then is processed by Digital Beamforming. The RF signal generated here is delivered to the PC Part to process it to provide diagnosis image such as BW, Color Doppler, PW Doppler, CW Doppler, and Power Doppler and display it on the monitor.

DC-DC Power module supplies power to the power of Ultrasound System Part.

Ultrasound System Part consists of the following components.

- CW (Continuous Wave Board)
- PSA(Probe Select Assembly)
- FE BD(Front End Board)
- BE BD(Back End Board)

5.3.3 User Interface Part

User Interface Part enables users to view ultrasound image on the LCD monitor and control SONOACE X6 through the control panel and touch panel.

The image output from the Back End Board is transferred to the LCD monitor and external device. Image output interface includes VHS, S-VHS, Composite, and DVI. In addition, the control panel enables users to easily operate the system through various interfaces.

The User Interface Part consists of the following components.

- LCD Monitor (LCD Inverter Board, LCD Interface Board)
- Control Panel Board
- Track Ball
- Alpha-numeric Keyboard

5.3.4 Power Part

It converts 110/230V AC voltage from external into DC voltage and supplies power to the DDM(DC to DC Power Module) of the Ultrasound System Part. ADM(AC to AC Power Module) provides power cut-off switch and fuse to prevent problem due to over-voltage.

5.4 PSA

5.4.1 Major Function

PSA (Probe Select Assembly) connects the system and probe.

It has 3 ea 156-Pin Array Probe Connector and 1 Static CW Static Probe Connector. The pins of Probe Connector are defined for Probe ID and HV-MUX control functions. And consist of Relay circuit to select one of 3 Array Probes. In addition, High Voltage Switching is applied so that the Front End Board's 48 Channel Signal and Probe's 128 Element are switched.

5.4.2 Block Diagram

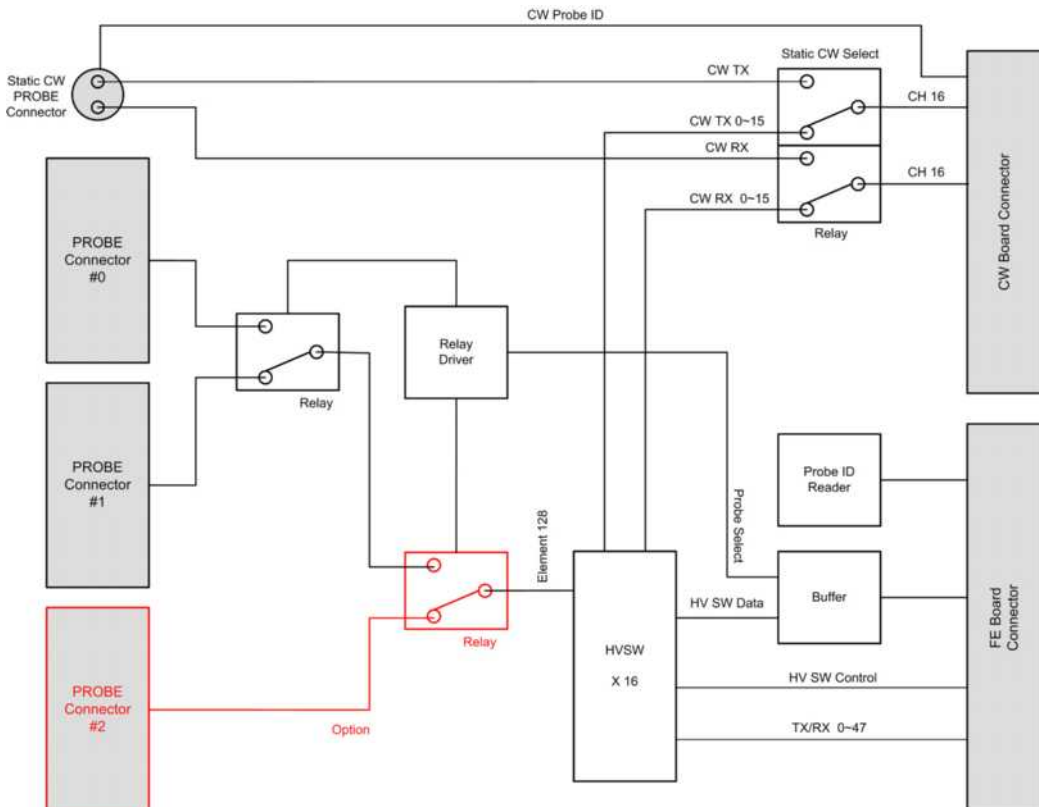

[Figure 5-2] PSA Diagram

5.4.3 Specification

- 48 Channel FE Board Support
- 16 Channel CW Board Support
- 156 Pin Array Probe Connector 3ea
- Static CW Probe Connector 1ea
- High Voltage Switching (48 Channel : 128 Element)
- Probe Switching (from FE)
- Probe ID Reader (to FE)
- Board Version Reader (to FE)

5.4.4 Operation Mechanism

5.4.4.1 High Voltage Switching Process

SONOACE X6 supports 48 Channels and 128 Elements Probes.

Since the FE BD's Pulser and Receiver circuit consists of 48 Channels only, additional Element Selection is necessary. Element Selection uses 16 High Voltage Switches and switches based on the Control Signal output from the FE BD's Control Logic(CPLD). Control Signal is connected through the Mother Board Connector.

High Voltage Switch consists of the Shift Register and High Voltage FET.

5.4.4.2 Probe Switching

It consists of circuit to select one of 3 probes. It can select a probe selected by the user by using Latched type relay. It drives the Relay with the Probe Select signal transmitted from the CW BD's Control Logic(CPLD). The Probe Select signal is connected through Mother Board Connector.

5.4.4.3 CW Probe Switching

Since Steered CW and Static CW are not done by FE BD and CW BD constructs Pulser and Receiver circuit, do Selecting by constructing an additional circuit when Steered CW and Static CW are used.

5.5 Front End Board

5.5.1 Major Function

Front End Board delivers High Voltage Pulser to a probe, generates ultrasound, amplifies the returned echo signal and does Digital Beamforming.

Active aperture is in charge of 48 Channel and supports up to 128 Element Probe. It consists of TX Pulser circuit, Receiving circuit and Beamformer ASIC(MCB024) to construct the Active aperture 48 Channels and does the Dynamic Apodization, Multi Beam Receiving, and TGC functions to enhance ultrasound image.

Non-CW(Continuous Wave Board) function provides System Clock Drive, Beamformer Sensing function, High Voltage Sensing function and PSA related signal.

5.5.2 Block Diagram

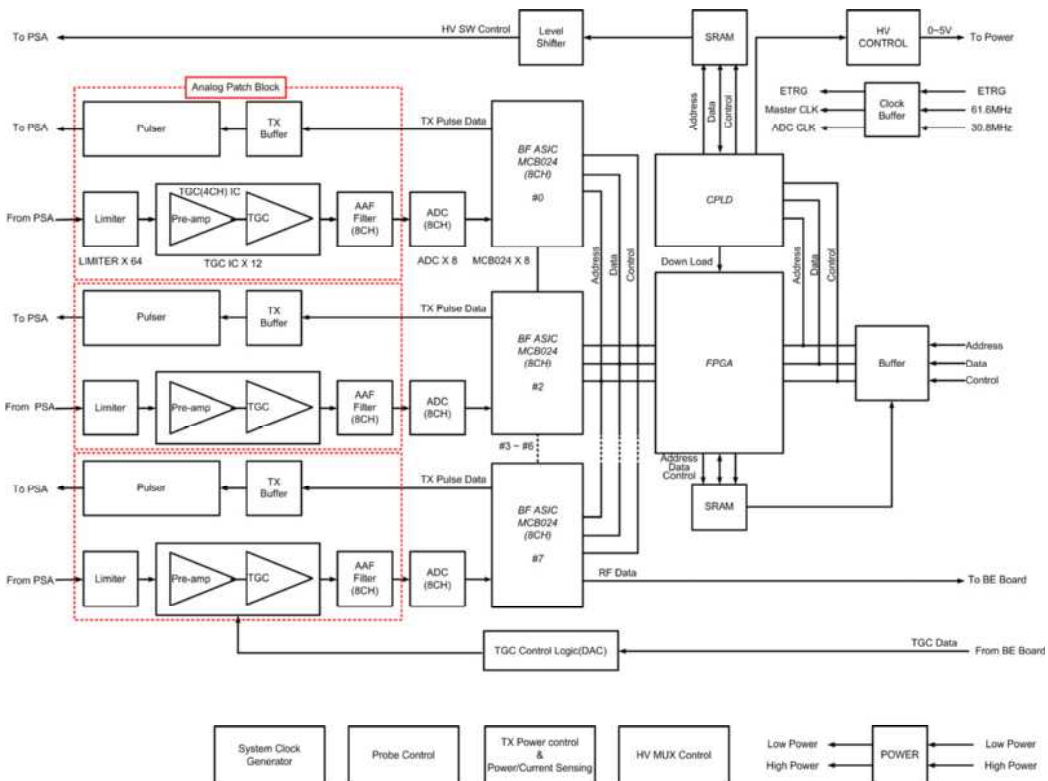

[Figure 5-3] Front End Board Diagram

5.5.3 Specification

Beamformer Part

- TX Pulser 48 Blocok
- Limiter 64ea
- TGC amp 16ea (4 Channels)
- AD converter 16ea (8 Channels)
- BF ASIC 8ea (MCB024)
- RX Dynamic Aperture Function
- RX Apodization Function
- Board Version Reader
- BFIC Operation Control Support
- PSA Probe Selecting Function
- Synthetic Aperture Support
- Trapezoidal Imaging Support
- Multi-Line Receiving Support
- TX Focal Point Support

Non CW Part

- Master Clock : System Clock Drive
- Beamformer Sensing
 - Beamformer High Voltage(+) Sense
 - Beamformer High Voltage(-) Sense
 - Beamformer High Current(+) Sense
 - Beamformer High Current(-) Sense
- Beamformer TX Control
- PSA related
 - Probe ID Read
 - Probe Insert Check
 - Probe Port Select

5.5.4 Beamformer Part Operation Mechanism

5.5.4.1 TX Pulser

The Exciting pulse data provided by BF ASIC(MCB024) is applied to TX Pulser Block via TX Pulse Buffer. TX Pulser Block generates Bipolar Pulser using the Exciting pulse data and the High Voltage from the DC-DC Power Module. Bipolar Pulser is sent to the Probe element by using the PSA to generate ultrasound.

Since Active aperture 48 Channels provide up to 128 Elements, additional Element Selection is necessary. For this purpose, High Voltage Switch is used. High Voltage Switch is constructed in PSA.

5.5.4.2 Receive Channel

Receive Channel amplifies echo that is penetrated through the medium of human body and the reflected, and does the role of Analog Digital Converter so that Beamforming can be conducted. It consists of Limiter, Pre-Amp, TGC-Amp, Low-Pass Filter and A/D Converter.

1) Limiter

It removes unnecessary signal from the Echo returned through the PSA (Probe Select Assembly)'s High Voltage Switch. Up to 180 Vpp Tx Pulses and a few mV Echo signals are mixed. Since actually necessary RX data is the echo signal of a few mV, Tx Pulse should be removed before the signal to the Pre-Amp. Limiter removes higher signal than approximately 0.6V and transfers the echo signal to the Pre-Amp.

2) Pre-Amp

Pre-Amp amplifies echo signal of a few mV that is not processed.

3) TGC-Amp

Each TGC(Time Gain Compensation) Amp consists of 4 channels. Since the echo signal that is penetrated and reflected by medium diminishes as it traverses, it compensates the attenuation of the signal.

4) Low Pass Filter(Anti-aliasing)

LPF filters noise in Stop Band that is out of ultrasound band. In addition, it does the role of Anti-aliasing Filter that minimizes the Aliasing Effect that may appear in a high frequency probe such as 7.5MHz probe. The Aliasing of high frequency probe occurs due to the limitation of the Sampling Clock in the BF ASIC.

5) A/D Converter

It converts the digital signal to be used in the Digital Beamforming into analog.

5.5.4.3 Digital Beamforming

The ultrasound generated by a probe takes channel mode that uses a number of elements for TX Focusing. The ultrasound generated by channel is penetrated through medium and reflected as echo signal. However, since echo signals do not return to Probe Element simultaneously, but they return with delay variation. Therefore, a countermeasure against the delays is necessary for RX Focusing and it is very important to construct ultrasound image.

Digital Beamforming samples the echo signal returned to Probe Element and save the

sampled data into the memory. The data saved in the memory when the sampling is complete means that time compensation is complete. The time compensation is done by the Sampling Clock itself. RX Focusing becomes complete, just by reading the data saved in memory and adding the data. Since this method requires different Sampling Clock for each element, VSCG(Variable Sampling Clock Generator) is necessary. VSCG(Variable Sampling Clock Generator) uses 61.6Mhz that is the same as A/D Sampling Clock and generates data necessary for BF ASIC(MCB024A).

5.6.4 Non CW Part Operation Mechanism

5.6.4.1 Master Clock

It provides 61.6Mhz Master Clock of the Ultrasound System Part to the CW Board, FE Board, and BE Board so that the boards can be synchronized.

5.6.4.2 Beamformer Sensing

Beamformer Sensing controls the TX voltage and current of FE Board. This function is executed in CPLD.

- 1) Beamformer High Voltage(+) Sense and Beamformer High Voltage(-) Sense
If the voltage of the TX Pulser used by FE Board fails to satisfy the specification, the system stops with an error message.
- 2) Beamformer High Current(+) Sense and Beamformer High Current(-)Sense
If the current of the TX Pulser used by FE Board fails to satisfy the specification, the system stops with an error message.

5.6.4.3 Beamformer TX Control

It controls the voltage of the TX Pulser of the FE Board. This function is executed in CPLD.

5.6.4.4 PSA Related

PSA related control functions also are executed in CPLD.

- 1) Probe ID Read
Reads Probe ID from the PSA and check the probe information.
- 2) Probe Inset Check
Identifies if a probe is installed from PSA.

3) Probe Port Select

Selects a probe according to the Probe Select signal when a command is issued to select a probe connected to PSA.

5.6 CW Board

5.6.1 Major Function

Continuous Wave Board support Continuous Wave Doppler function. Continuous Wave Doppler function is optional.

5.6.2 Block Diagram

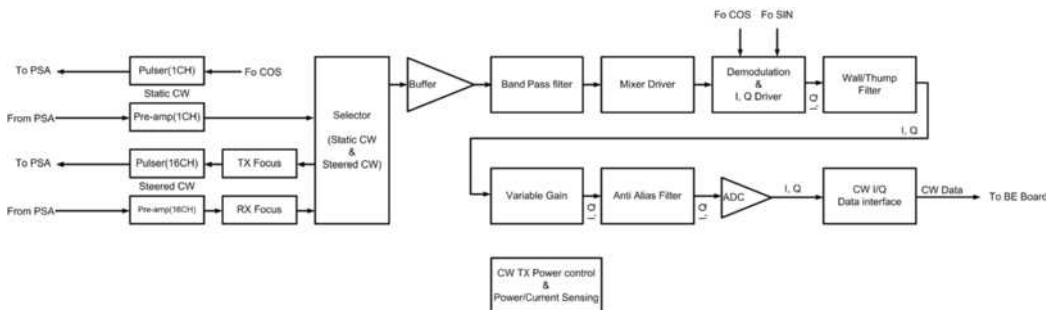

[Figure 5-4] CW Board Diagram

5.6.3 Specification

- Continuous Wave Doppler (CW Option)
 - Static CW Doppler TX/RX
 - Steered CW Doppler TX/RX
- CW Sensing (CW Option)
 - CW TX Voltage Sense
 - CW TX Current Sense
- CW TX Control (CW Option)

5.6.4 Operation Mechanism

5.6.4.1 Continuous Wave Doppler

Continuous Wave Doppler processes TX and RX continuously and detects Doppler signal that cannot be detected by Pulse Wave Doppler. SONOACE X6 does this function in the CW(Continuous Wave Board) and constructs Static CW and Steered CW circuit.

1) Static CW Doppler Circuit (TX/RX 1Channel)

- ① CW Pulser that drives Transducer
- ② RF Pre-Amplifier for signal reception

- ③ Mixer to convert RF signal into vertical phase (0 degree, 90 degree) base band signal of 50KHz bandwidth
 - ④ Thump Filter
 - ⑤ Variable Wall Filter
 - ⑥ Variable Gain
 - ⑦ Variable Low Pass Filter
 - ⑧ Analog-To-Digital Converters
- 2) Steered CW Doppler Circuit (TX/RX 16 Channel)
- ① 16 Channel CW Pulser that drives Transducer.
 - ② 16 Channel RF Pre-Amplifier for signal reception
 - ③ TX/RX Beamformer for TX and RX Focusing
 - ④ Mixer to convert RF signal into vertical phase (0 degree, 90 degree) baseband signal of 50KHz bandwidth
 - ⑤ Thump Filter
 - ⑥ Variable Wall Filter
 - ⑦ Variable Gain
 - ⑧ Variable Low Pass Filter
 - ⑨ Analog to Digital Converters

5.6.4.2 CW Sensing

It controls the TX voltage and current of CW(Continuous Wave).

1) CW TX Voltage Sense

If the voltage of the TX Pulser used by CW(Continuous Wave) fails to satisfy the specification, the system stops with an error message.

2) CW TX Current Sense

If the current of the TX Pulser used by CW(Continuous Wave) fails to satisfy the specification, the system stops with an error message.

5.6.4.3 CW TX Control

Controls the voltage of the CW(Continuous Wave)'s TX Pulser.

5.7 Back End Board

5.7.1 Major Function

Back End Board (hereafter, BE Board) consists of DSP Part(Digital Signal Processing), DSC Part(Digital Scan Converter), VM Part(Video Manager) and PC Part, in addition to a Analog Sound Part.

The DSP Part receives RF data and CW I/Q Data from the FE Board and CW Board respectively, processes the data and outputs the data as image data such as BW Image, PW Doppler, CW Doppler, Color Doppler, and Power Doppler

The DSC Part receives doppler data and BW data(2D and M), which are saved in the DSC Part. the data is then scan converted and send the Video Manager at appropriate Vsync and H sync.

The Video Manger displays the VGA 1024 X 768 image on the monitor screen. An area of 512 X 440 only is allocated for displaying ultrasound images

Analog Sound Part processes the Doppler Sound Data from the DSP Part, with the Digital Analog Converter, amplifies the signal and sends it to the speaker.

In order to operate the PC Module, an industrial PC is usually incorporated into the system. Operating system in use Linux, which supports a wide array of peripherals.

BE Board consists of MID processor(MCB025), Color processor(MCB026), DSP FPGA, DSC FPGA, VM FPGA, DSP processor, and CPLD.

5.7.2 Specification

DSP Part

- BW mode (B-Mode) Image Data Processing
- Motion mode (M-mode) Image Data Processing
- Color Flow Mapping mode (CFM-mode) Image Data Processing
- Color Frame Rate (CFR) Image Data Processing
- Directional Power Doppler Image Data Processing
- Pulsed wave (PW) spectral Doppler Image Data Processing
- Synthetic aperture Support
- Tissue Doppler Imaging Support
- Multibeam processing Support
- Tissue Harmonic Imaging Support
- Speckle Reduction filter(SRF) Support
- Extreme High Dynamic Range (170dB) Support

- Full Spectrum Imaging (FSI) Support
- High Pulse Repetition Frequency (HPRF) Support

DSC Part

- Frame Average Processing
- Real Time Controller (RTC) Processing
- ECG Interface
- Digital Scan Converter
- Cine for 512 frame
- Loop Review for 4096 lines
- Zoom
- Edge Enhancement
- Freehand 3D
- Quick Scan

VM Part

- Image Sync Generation
- BW, Loop Dual Display Windows Generation
- Image Header Mapping (BW, M, Doppler, Color)
- ECG Image Mapping
- Image Grabber Memory (Gray Bar, B Dual, B/Loop, Sonoview data)
- Field Memory (Video Frame Memory)
- DVI(VGA) Out
- Interlace VGA Out
- Interlace CV Out

PC Module

- Model : SOM-4455 (Company : Advantech)
- CPU : Embeded AMD Geode LX800-500 Mhz

5.7.3 Block Diagram

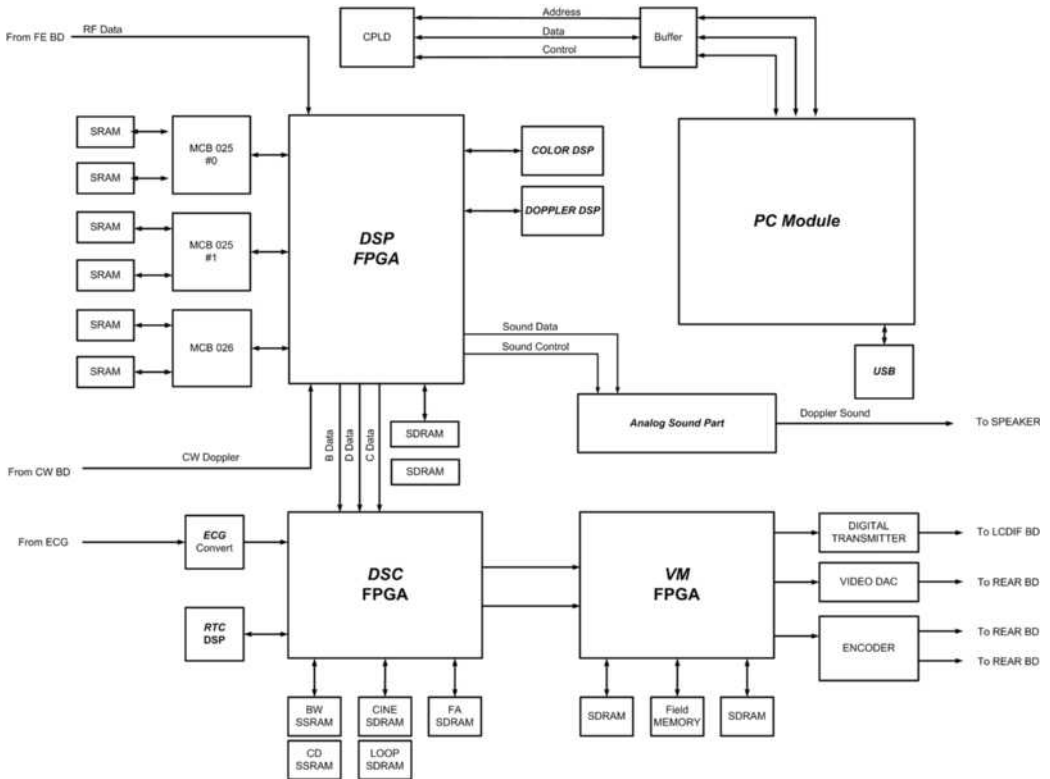

[Figure 5-5] Back End Board Block Diagram

5.7.4 DSP Part Operation Mechanism

5.7.4.1 BW Mode and M Mode Image Data Processing

RF data generated in the BF Board is input to the DSP FPGA.

The input RF data is converted into RF data, which can be processed by the MID Processor (MCB025), and input to the MID Processors (MCB025 #0, #1).

The 3 MID Processors (MCB025 #0, #1) generate BW mode image data (hereafter, BW Data) and send the data to the DSP FPGA. The 3 MID Processors (MCB025) are used to implement FSI(Full Spectrum Image) function that has 3 bands. The final processing of FSI(Full Spectrum Image) function is worked in the DSP FPGA.

MID Processors (MCB025 #0, #1) not only generate BW data but also do the functions of FSI(Full Spectrum Image) and Synthetic Aperture.

Especially, BW data is generated by using the received RF data and through the

DTGC(Digital Time Gain Compensation), Decimation, Quadrature mixer, Envelope detection, Log compression and various filters.

The BW data generated by MID Processors (MCB025 #0, #1) as described above are input to the DSP FPGA again. The data are processed by FSI(Full Spectrum Image) and Lateral filter, which is used to remove Multibeam artifact, and sent to the DSC Part.

For your reference, BW data can also be used as Motion Mode Image Data.

5.7.4.2 Doppler Image Data Processing

The RF data generated in the FE Board is the DSP FPGA.

The input RF data is converted into RF data that can be processed by the MID Processor (MCB025) and input to the MID Processor (MCB025) #1.

MID Processor (MCB025) #1 receives RF data and does the DTGC (Digital Time Gain Compensation), Decimation, and Quadrature mixer processing for the RF data . The RF data becomes I/Q data (In-phase & Quadrature Data). I/Q data are input to the DSP FPGA again.

I/Q data are processed by the DSP FPGA and Doppler DSP and become Doppler Data and are sent to the DSC Part. Detailed descriptions are given below.

The DSP FPGA that received the I/Q Data, sends the data to the Doppler DSP via filtering. At this time, the CW I/Q Data from the CW Board also sends final Doppler Data to the DMA & RTC Part through the same process as above. Since both PW and CW data cannot be processed simultaneously, all commands follow internal control process.

I/Q Data passes through the Clutter Filter in the Doppler DSP to remove the Wall (blood vessel wall) Noise after the data are filtered by the DSP FPGA. After that, the Doppler Sound is generated through the Hilbert transform that separates sound directions. The data are input to the DSP FPGA again and is sent to the Analog Sound Part.

In addition, I/Q Data are sent to the FFT (Fast Fourier Transform) circuit to generate the Doppler Spectrum, after passing through the Clutter Filter. By extracting the basic Doppler components of Power, Velocity, and Variance components, the Doppler Data are generated. The data are input to the DSP FPGA again and is sent to the DSC Part.

5.7.4.3 Color Image Data Processing

RF Data generated in the FE Board are input to the DSP FPGA.

The input RF data are converted into RF data that can be processed by the MID Processor (MCB025) and input to the MID Processor (MCB025) #0.

MID Processor (MCB025) #0 receives RF data and does the DTGC(Digital Time Gain Compensation), Decimation, and Quadrature mixer processing for the RF

data . The RF data becomes I/Q data (In-phase & Quadrature Data). I/Q data are input to the DSP FPGA again.

I/Q Data generate Color Data through the processing in the Color Processor (MCB026A) and the data are sent to the DSC Part. Detailed descriptions are given below.

The DSP FPGA receives the I/Q Data, sends the data to the Color Processor (MCB026) to extract color components. However, since the color component include Wall (blood vessel wall) Noise, the data are sent to the DSP FPGA again and passes through the Rejection, Smooth Filter, and Post Filter. Color Data are completed in the process and sent to the DSC Part.

5.7.5 Analog Sound Part Operation Mechanism

Processes the Doppler Sound and outputs to the speaker.

Doppler Sound is generated in the Doppler Part and is sent to the Analog Sound Part. Doppler Sound passes through Audio Digital Analog Converter because the speaker requires analog signal. In addition, the control of the Audio Digital Analog Converter is supported by the DMA & RTC Part.

After that, the noise is removed and Doppler Sound is amplified and sent to the speaker via the PWR Switch Board.

5.7.6 DSC Part Operation Mechanism

The DSC Part is an image filter circuit that improves image quality. It consists of the screen conversion part which writes the received scan line data reads the monitor by the H-sync cycle, frame memory part, and zoom and freehand 3D path parts.

The DSC Part sums data from 2D mode and spectral Doppler mode produced by different paths together as one set of common data.

It facilitates various functions such as Digital Scan Conversion and Frame Average, 3D(DMA), Cine, RTC, Read Zoom, and Edge Enhance along with Memory.

DMA (Direct Memory Access) consists of FA(Frame Average), DMA and ECG In/Out Part.

Since DMA processes data using the DMA path with the PC Module, it plays key role to improve the product performance.

RTC(Real Time Controller) generates base signal necessary for entire system operation in real-time and controls the system operations. It generates and controls the PRF (Pulse Repeat Frequency), OF(One Frame), RP(Rate Pulse), Line Type, and Scan Line signals necessary for the FE Board and BE Board's DSP Part. In addition, it internally controls the data flow in the DMA FPGA.

5.7.7 VM Part Operation Mechanism

The Video Manger Part converts the image data received from the DSC Part into Video image for displaying on the monitor and key it in with PC's VGA data. The keyed data is turned into interlace and non-interlace signals for displaying the final output through a VGA monitor, interlace monitor, echo printer, etc.



[Figure 5–6] LCD Display

- LCD Resolution: 1024 x 768
- Area 1 : Menu and Navigation.
- Area 2 : Image Area and VCR output area. (Size: 640 x 440)
- Area 3 : Thumbnail Area.
- Area 4 : Sub Menu Area.
- Area 5 : Soft Menu and Information Tab Area.

5.7.8 PC Module Operation Mechanism

5.7.8.1 PCI/Local Bus Interface

PCI/Local Bus Interface connects to the PCI bus of the CPU, converting it into a Local Bus so that various devices in the Local bus can be allocated in absolute address ranges for their direct use.

5.7.8.2 Peripheral Port Interface

2 IDE (Ultra DMA33)

1 Parallel

2 Serial

Rear Panel Signal

LCD Panel Part

4 USB (2.0/1.1 compliant)

Ethernet (100M BASE-T Ethernet)

5.8 Rear Board

5.8.1 Major Function

Does the Input/Output function with external devices.

5.8.2 Block Diagram

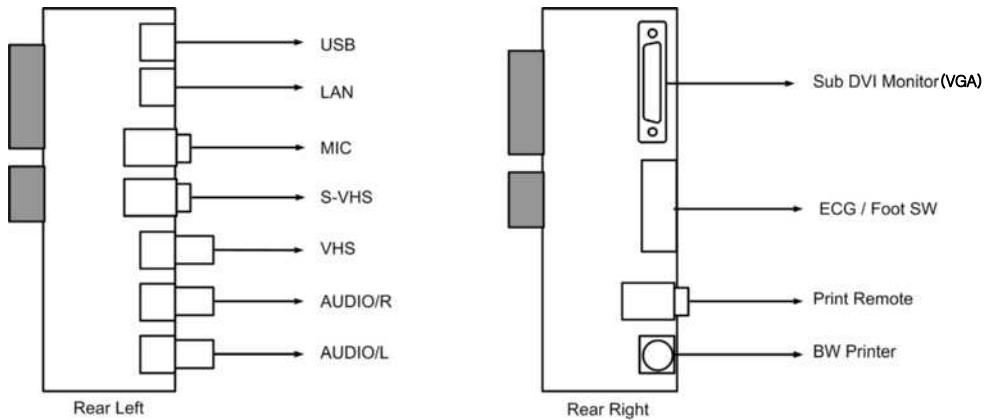

[Figure 5-7] Rear Board Block Diagram

5.8.3 Specification

- USB Ports (2 ea)
External USB Devices (ex. MO)
USB Version 1.0
- LAN Port
- B/W Output (NTSC or PAL)
- S-VHS Output (NTSC or PAL)
- VHS Output (NTSC or PAL)
- MIC Input
- Remote Output (BW Echo Printer)
- 2ch Sound Outputs
- DVI 1024 X 768 (With VGA)

5.9 Control Panel

5.9.1 Major function

It plays the role of the interface between the user and the system.

Control Panel Board, Alpha-numeric Keyboard, and Track Ball do the role of User Interface.

5.9.2 Block Diagram

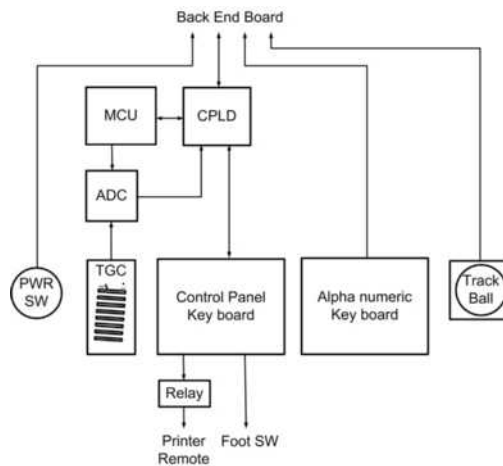

[Figure 5-8] Control Panel Block Diagram

5.9.3 Specification

- Alpha Numeric Board
- Track Ball
- Control Panel Key Matrix Board
- TGC Control
- Power Control Support
- Printer Remote Support
- Foot Switch Support

5.9.4 Operation Mechanism

It is connected with the Control Panel Key Board and TGC through the MCU and operate according to the user's commands. Alpha-numeric Board and Track Ball is connected with the BE Board

5.10 Power Supply

5.10.1 AC to DC Power Module

SONOACE X6 is designed so that it operates when the input voltage is either 110V or 220V.

You have to select the input voltage selector of the product before using it according to the input voltage to be connected to the product.

The INPUT Voltage Selector is used to determine the power and voltage to be supplied for the product, and the OUTPUT Voltage Selector is used to determine the power to be directly supplied to the external devices.

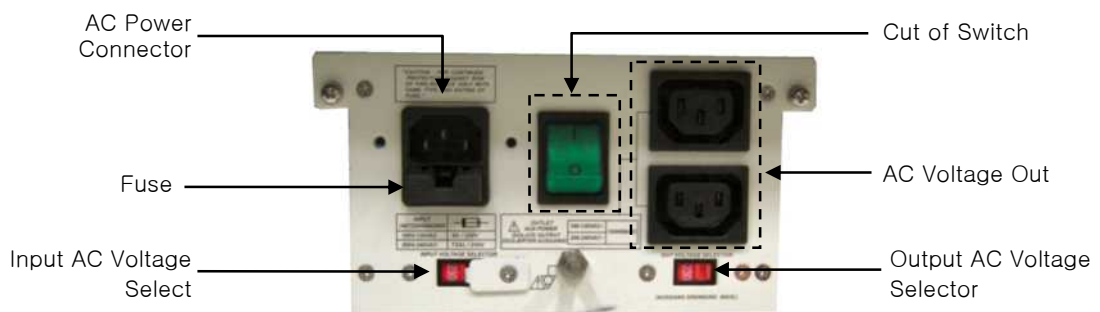

Standard Voltage	Input Frequency	Allowed Range
115 V	50 ~ 60 Hz	90 ~ 120 V
220 V	50 ~ 60 Hz	200 ~ 240 V

[Figure 5–9] AC to DC Power Module

5.10.2 DC to DC Power Module

DDM receives power from ADM and supplies power to the Ultrasound System Part. Protection circuit in the DDM provides information through the Alarm Display of the ADM when a problem is detected.

The power unit of the SONOACE X6 has the following features

- Power sequence control function using Mycom
- Voltage channels of various ranges and stable and consistent out voltage in each channel.
- The output voltage display allows the user to check power-related errors.
- High-performance monitoring of various errors (over current, over voltage, output short-circuit, low voltage, etc) by Mycom
- Power protection function.

5.10.2.1 Output Voltage

Output voltage	Rated Current
+3.5V	12A
+5.2V	10A
-5.2V	1A
+12.2V	4A
-12.2V	0.8A
+15V	1A
+HV	0.2A
-HV	0.2A
+97V	0.1A
-97V	0.1A

5.10.2.2 Alarm Display

You can identify DC to DC Power Module by watching the Display LED



Alarm LED	LED ON
OLP	Over-Current
OVP	Over-Voltage
OTP	Over-Temperature
Output voltage	Normal

[Figure 5-10] DC to DC Power Module Alarm Display

1) OLP (Over Current Protection)

If current flows in the Over-Current Range exceeding the standard input and max output current, the OLP is activated and all powers of DDM are cut off.

Output Voltage	Over-Current Range
+3.3V	24A ~ 40A
+5V	15A ~28A
-5V	Protection Short
+12V	4A ~ 9A
-12V	Protection Short
+97V	Protection Short
-97V	Protection Short
+HV	Protection Short
-HV	Protection Short

2) OVP (Over Voltage Protection)

If current flows in the Over-Voltage Range exceeding the standard input and max output voltage, the protection circuit is activated and all powers of DDM are cut off.

Output Voltage	Over-Voltage Range
+3.3V	+3.63V ~ +4.29V
+5V	+5.5 ~ +6.5V
-5V	-5.5 ~ -6.5V
+12V	+13.2 ~ +15.6V
-12V	-13.2 ~ -15.6V
+97V	+88V ~ +110V
-97V	-88V ~ -110V
+HV	+106 ~ +110V
-HV	-106 ~ +110V

3) OTP (Over Temperature Protection)

If the temperature of the DDM Case is equal to or higher than 80°C, all powers of DDM are cut off.

4) Output Voltage Check (5V, 12V, 97V, HV)

All LED lights are green in normal condition. In case of an error, the main power id disconnected, LED's are turned off, and yellow LED for the given error is turned on.

6 Basic Maintenance

6.1 Overview

Chapter 6 describes basic SONOACE X6 maintenance procedures.

How to upgrade and how to use Admin Mode (Service Mode) are described.

Contents Basic Maintenance

6.1	Overview	6-1
6.2	System Information	6-2
6.3	Entering Admin Mode	6-3
6.4	Upgrade	6-6
6.4.1	Software Upgrade	6-6
6.4.2	Hardware Upgrade	6-9
6.5	Backup & Restore	6-10
6.5.1	Backup User Setting	6-10
6.5.2	Restore User Setting	6-11
6.6	Adding and Deleting Options	6-13
6.6.1	Option type	6-13
6.6.2	Registering Options	6-13
6.6.3	Deleting Options	6-14
6.7	Control Panel Test	6-15

6.2 System Information

To view system information, select the [Information] tab in the Setting window. The software version of the system will be displayed. Press [Detail] to view the detailed version information of the product.

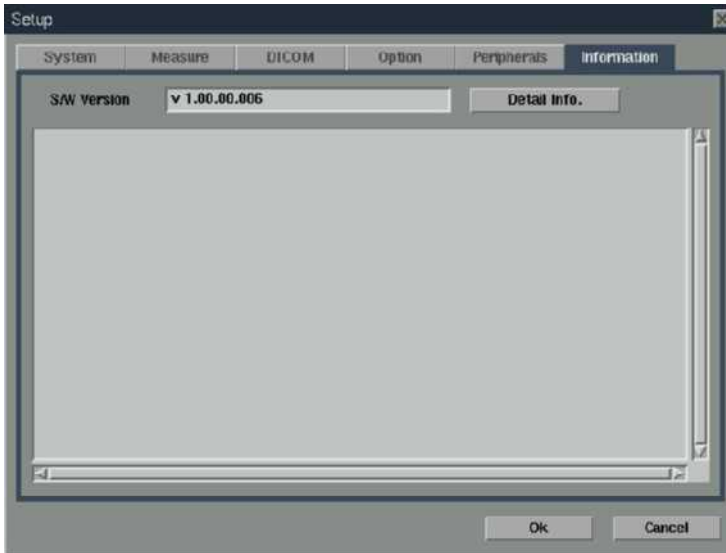

[Figure 6-1] Setting-Information

NOTE The software version number in the above figure may differ from the actual software version of the system.

6.3 Admin Mode

Admin mode is also called service mode. Admin mode functions are described below.
Admin mode is necessary for Upgrade and Backup & Restore.

6.3.1 Entering Admin Mode

- 1) You have to enter a password with a combination from the alphanumeric keyboard in order to enter Admin Mode
- 2) In Live mode, enter the admin password “[***] + [***] + [***] + [***]” and the admin mode popup will appear as shown below. You must keep the “[***]key” held down until the complete admin password is entered.
- 3) Enter the password “*****” in the admin mode popup to enter admin mode.

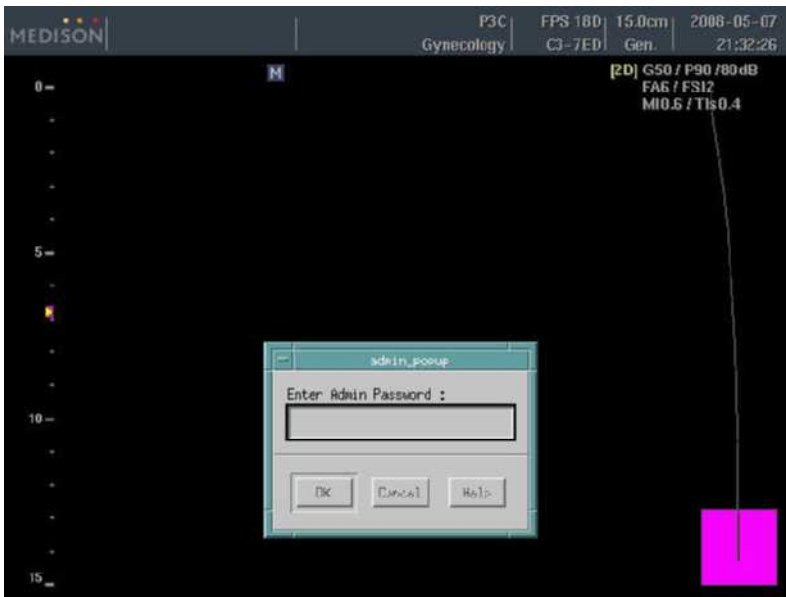

[Figure 6-2] Admin popup

6.3.1 Admin Mode Functions

This section describes admin mode

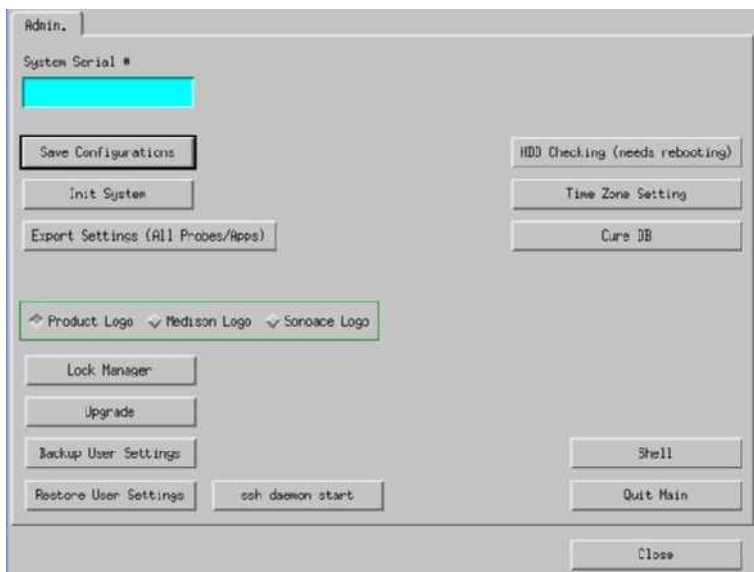

[Figure 6-3] Admin mode

6.3.2.1 System Serial

Enter the System Serial No. in system serial #.

6.3.2.2 Save Configurations

Saves all settings in the system.

6.3.2.3 Init System

Initializes the system back to the factory default settings.

6.3.2.4 Export Setting (All Probe/Apps)

R&D only

6.3.2.5 Logo

Supported logo is Product Logo, Medison Logo and SONOACE Logo.

6.3.2.6 Lock Manger

R&D only

6.3.2.7 Upgrade

Referring to “6.4.1 Soft ware Upgrade”.

6.3.2.8 Backup User Settings

Referring to “6.5.1 Backup user Setting”.

6.3.2.9 Restore User Settings

Referring to “6.5.2 Restore User Setting”.

6.3.2.10 Ssh daemon start

R&D only

6.3.2.11 HDD Checking (needs rebooting)

Checks the hard disk for any problems.

6.3.2.12 Time Zone Setting

Setup can determine the correct time zone

6.3.2.13 Cure DB

R&D only

6.3.2.14 Vkey

Referring to “6.7 Control Panel Test”.

6.3.2.15 Shell

R&D only

6.4 Upgrade

You can upgrade the software and hardware of SONOACE X6.

Upgrade includes the addition and improvement of functions and improves system performance.

NOTE

- The installed software should be compatible with the hardware. If the installed software and hardware are not compatible, a problem may occur in functions or operations.
- A compatibility table is additionally provided by the customer service department of MEDISON Co., Ltd.

6.4.1 Software Upgrade

Follow these instructions to software upgrade the system.

- 1) Prepare a software file provided by the customer service department of MEDISON
- 2) Turn on SONOACE X6.
- 3) When system booting is complete, enter admin mode referring to “6.3.1 Entering Admin Mode”
- 4) Insert a CD/DVD into the CD/DVD-ROM drive or insert a Fresh Memory or MO into the USB port.
- 5) Press the upgrade button in the Admin mode.
- 6) Select the drive in the upgrade popup.

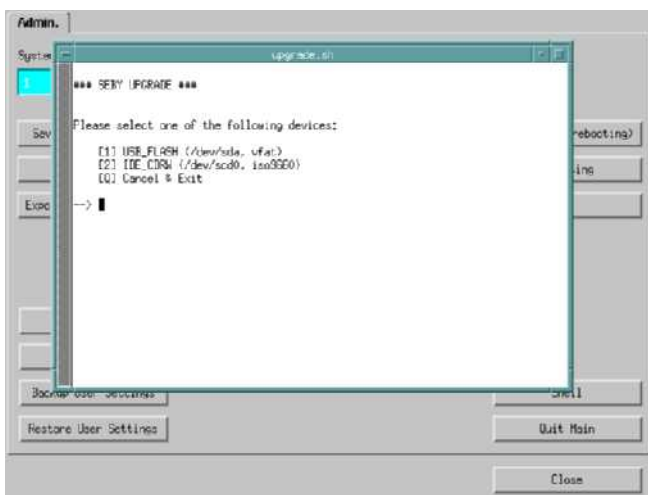

[Figure 6-4] Upgrade – popup

7) Select the upgrade version. [Figure 6-5]

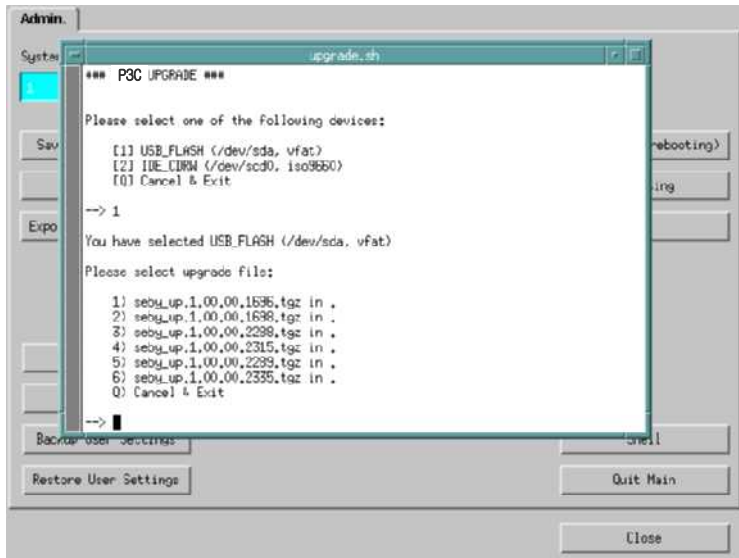

[Figure 6-5] Upgrade-Select Upgrade

8) Select "y" for the correct file.

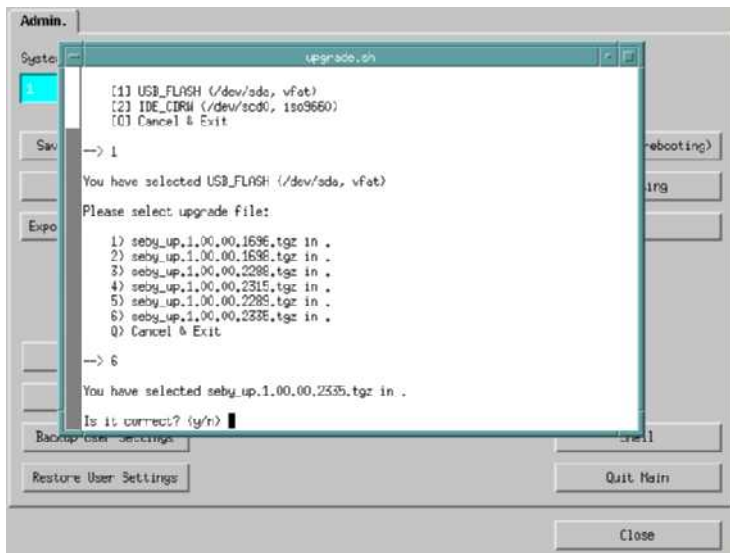

[Figure 6-6] Upgrade-Connect Upgrade

6.4.2 Hardware Upgrade

This means the replacement or addition of hardware.

NOTE For information on hardware upgrade, refer to the “Chapter 8 Disassembly and Reassembly” of the Service Manual.

6.5 Backup & Restore

Follow the instruction to backup and restore user setting values.

6.5.1 Backup User Setting

Using this function, you can backup your user settings onto external media. This function is available only in the Admin Mode.

- 1) Turn on SONOACE X6.
- 2) When system booting is complete, enter admin mode referring to “6.3.1 Entering Admin Mode”
- 3) Insert a CD/DVD into the CD/DVD-ROM drive or a Fresh Memory or MO into the USB port.
- 4) Press the Backup User Settings button in the Admin mode.
- 5) Select the drive in the Backup User Settings pop-up and press the start button.
- 6) The system asks about Backup DB data. Press “yes” or “no”. [Figure 6–9]

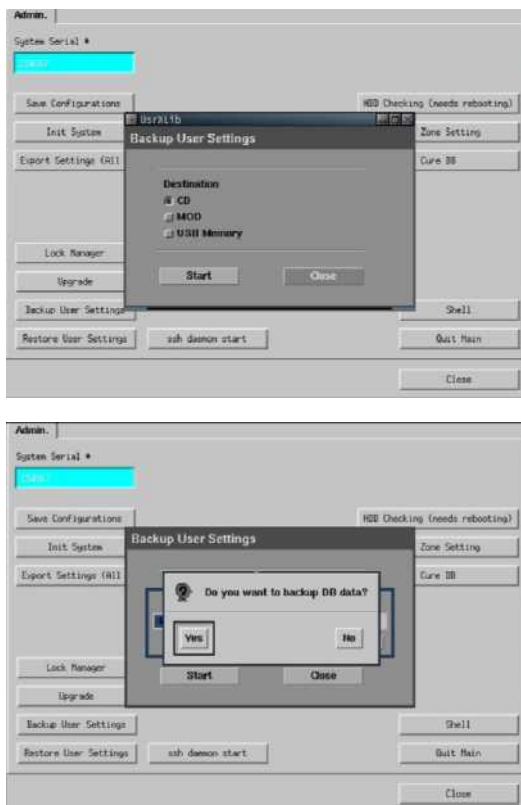

[Figure 6–9] User Setting–Backup

7) Backup again message

① CD/DVD Destination

The CD media check progress bar will appear, Checking the media. When bar reaches 100%, the PC Write Progress bar will appear and the system will start writing to the CD. When the bar reaches 100%, the CD Writing Complete windows and the OK button will appear. Press the OK button to close the windows.

② MO or USB Memory Destination

The Progress bar will appear and the system will start writing to the MO/USB memory, When the bar progress 100%, the OK button will appear, Press the OK button to close in window.

③ Message appears when medium does not exist.

The following message will appear if the medium is not ready.



[Figure 6-10] User Setting-Backup

6.5.2 Restore User Setting

Using this function, you can restore your user settings onto external media. This function is available only in the Admin Mode.

- 1) Turn on SONOACE X6.
- 2) When system booting is complete, enter admin mode referring to “6.3.1 Entering Admin Mode”
- 3) Insert a CD/DVD into the CD/DVD-ROM drive or a Fresh Memory or MO into the USB port.
- 4) Press the Restore User Settings button in the Admin mode. [Figure 6-11]

- 5) Select the drive in the Restore User Settings pop-up and press the start button.
- 6) The Progress bar will appear and the system will start decompressing restore data into the temp directory.
- 7) When the bar progress is 100%, Press the close button to close window.

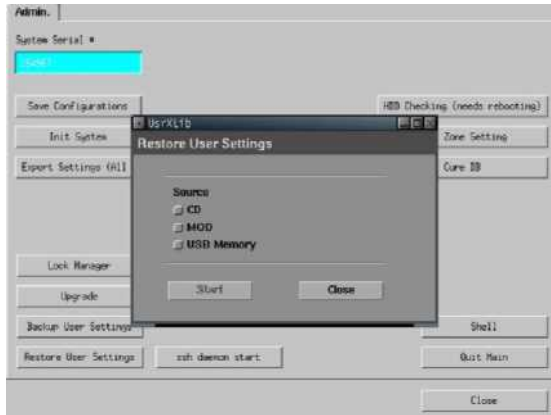

[Figure 6-11] User Setting-Restore

6.6 Adding and Deleting Options

This section describes how to add and delete options from SONOACE X6.

Adding and Deleting Options consist of Unlock / Lock types. Unlock means a state in which an option is available, while Lock means a state in which an option is unavailable.

Options are classified into software and hardware type. You can view the contents of an option in the Setup Mode.

6.6.1 Option Types

SONOACE X6 options become available by entering an Option Password or installing hardware.

For option types and registration methods, refer to the following table.

Option	Registration Method (Unlock)
Image Filing	Entering Option Password
DICOM	Entering Option Password
Freehand 3D	Entering Option Password
Pulse wave Doppler	Entering Option Password
Color Doppler	Entering Option Password
Cardiac S/W Package	Entering Option Password + CW Board Install
ECG	ECG Install

[Table 6-1] Option Types

6.6.2 Registering Options

6.6.2.1 Entering Option Password

Procedures to register (Unlock) an option by entering a password will be described below.

- 1) Select the Option tab in setup mode.
- 2) Select an option to be added and enter the password.
- 3) If the entered password is correct, press the [OK] button and restart the system.

6.6.2.2 Registering ECG Option

If you add the ECG Module and select [ECG "on"] in the activated ECG Menu, the ECG Option is registered (Unlock).

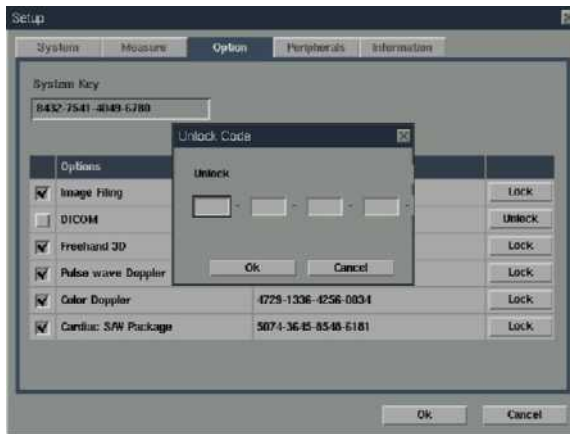

[Figure 6-12] Registering Options

6.6.3 Deleting Options

Procedures to delete options are described below.

- 1) Select the Option tab in setup mode.
- 2) Select an option to be deleted, and enter the password.
- 3) If you have deleted a password, click the [OK] button and then restart the system.

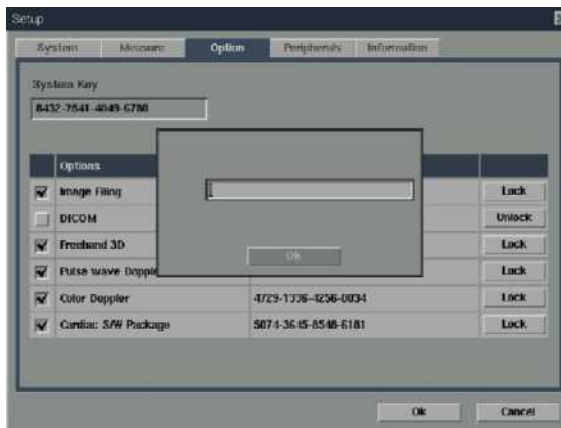

[Figure 6-13] Deleting Options

6.7 Control Panel Test

This section describes how to test control panel from SONOACE X6.

- 1) Turn on SONOACE X6.
- 2) When system booting is complete, enter admin mode referring to "6.3.1 Entering Admin Mode"
- 3) Select the Vkey button in Admin mode.
- 4) Start the Control panel Test in the Vkey pop.
- 5) When test is complete, Press the exit button to close in window.

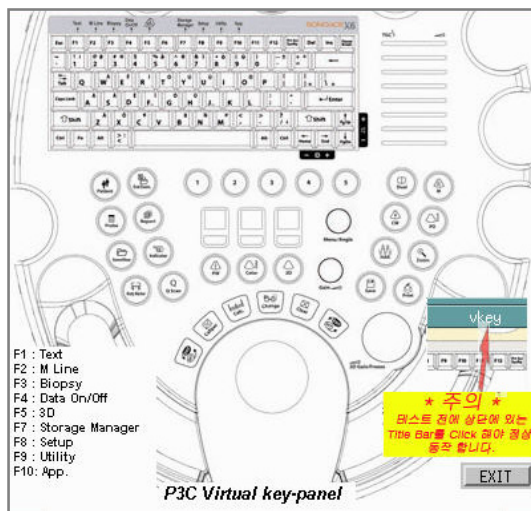

[Figure 6-14] Virtual key-panel

7 Troubleshooting

7.1 Overview

Chapter 7 describes basic troubleshooting procedures.

NOTE Procedures for troubleshooting expected problems are described. Unexpected situations may occur.

Procedures for troubleshooting normal problems are described.

Contents Troubleshooting

7.1	Overview	7-1
7.2	Power	7-2
7.2.1	Power Failure	7-2
7.2.2	Power cannot be turned off	7-2
7.2.3	Power is automatically turned off	7-3
7.3	Monitor	7-4
7.3.1	Blank Screen	7-4
7.3.2	Screen Color is Abnormal	7-4
7.4	Error Messages	7-5
7.4.1	System hangs after an error during booting	7-5
7.4.2	System works even if error occurred	7-5
7.5	Image	7-6
7.5.1	No BW Image Echo	7-6
7.5.2	No BW Mode Image Format	7-6
7.5.3	Noise Link Rain over the BW Mode Image (Noise)	7-6
7.5.4	PW Doppler Mode Trouble	7-7
7.5.5	CW Doppler Mode Trouble	7-7
7.5.6	Color Doppler Mode Trouble	7-7
7.5.7	Motion Mode Trouble	7-7

7.2 Power

7.2.1 Power Failure

This may occur if the power cord is not properly connected or the Power Supply is not working.

- 1) Check if the power cord is properly connected and if the cut-off switch of the ADM is turned on.
- 2) Check the fuse status.
- 3) Connect another device to the wall outlet and check if it works.
If the device works, there is a Power Supply problem.
If the device does not work, the problem is down to the wall outlet.
- 4) Check if the system fan works.
If the fan works, the problem is not a power supply problem.
If the fan does not work, a PC Power problem is likely.
- 5) Disconnect the power cord and connect it again after 1 or 2 minutes.
- 6) Check the input and output voltage of the ADM.
- 7) Check the PC Power Supply and DDM.

7.2.2 Power cannot be turned off

A software error or PC Motherboard or Control Panel Board problem is likely.

- 1) The power is automatically turned off when the Power Switch is pressed for more than 3 seconds. If software such as printer software is running or an operating system error occurs, the power is not turned off.
- 2) If you cannot turn the power off after completing the procedures in 1), a PC Motherboard or Control Panel Board problem is likely.

7.2.3 Power is automatically turned off

Power cord, PC Mother Board or Control Panel Board trouble is expected.

- 1) Check if the power cord is properly connected and if the cut-off switch of ADM is turned on.
- 2) Check the fuse status.
- 3) Connect another device to the wall outlet and check if it works.
If the device works, it is due to ADM problem.
If the device does not work, it is due to wall outlet problem.
- 4) If the power is automatically turned off after completing the procedures of “1), 2), and 3)”, PC Mother Board or Control Panel Board trouble is expected.

7.3 Monitor

7.3.1 Blank Screen

DVI Cable is improperly connected or monitor, BE Board or Mother Board trouble is expected.

- 1) Try to print to check the product status.
If printing is normal, monitor or BE Board trouble is expected.
- 2) Check the cable is properly connected with the monitor.
Check the DVI Cable connection of the Mother Board and monitor.
- 3) If no problem has been found in the above “1) and 2)”, BE Board or Mother Board trouble is expected.

7.3.2 Screen Color is Abnormal

DVI Cable of the monitor or PC Part is improperly connected or monitor or PC Part trouble is expected.

- 1) Check the monitor connection cable status.
Check the DVI Cable connection of the Mother Board and Monitor.
Check the Mother Board and BE Board.
- 2) If no problem has been found in the above “1)”, BE Board or Mother Board trouble is expected.

7.4 Error Messages

7.4.1 System hangs after an error during booting

Temporary software error or product trouble is expected.

- 1) Turn the power off by force and then turn it on again after 1 to 2 minutes.
- 2) If the symptom continues after completing “1)”, check when the error message appears.

If the error message appears while Linux is running, operating system or PC Part trouble is expected.

If the error message appears after SONOACE X6 logo appears, system software or Ultrasound System Part trouble is expected.

7.4.2 System works even if an error occurred

Temporary software error or product trouble is expected.

- 1) Turn the power off by force and then turn it on again after 1 to 2 minutes.
- 2) If the symptom continues after completing “1)”, check when the error message appears.

If the error message appears while Linux is running, operating system or PC Part trouble is expected.

If the error message appears after SONOACE X6 logo appears, system software or Ultrasound System Part trouble is expected.

7.5 Image

7.5.1 No BW Mode Image Echo

Probe and the system connection, FE Board or DDM trouble is expected.

- 1) Check the connection between the probe and the system.
- 2) Check if probe oscillation sound is heard.
If oscillation sound is heard, the problem may be DDM trouble.
- 3) Check if the NOR Alarm LED of ADM is on.
If NOR LED is on, DDM is normal.
If OVP, OLP or OTP LED is on, the problem is DDM trouble.
- 4) If no problem has been found in the above “1), 2), and 3)”, FE Board trouble is expected.

7.5.2 No BW Mode Image Format

Probe and the system connection or BE board trouble is expected.

- 1) Check the connection between the probe and the system.
- 2) Check if probe oscillation sound is heard.
If oscillation sound is heard, the problem may be DDM trouble.
- 3) Check if the NOR Alarm LED of ADM is on.
If NOR LED is on, DDM is normal.
If OVP, OLP or OTP LED is on, the problem is DDM trouble.
- 4) If no problem has been found in the above “1), 2), and 3)”, BE board trouble is expected.

7.5.3 Noise Like Rain over the BW Mode Image (Noise)

Power noise or FE Board trouble is expected.

- 1) Check if the system shares the wall outlet with another device.
If the system shares the wall outlet with a device that uses electric motor or consumes high power, noise may be generated.
- 2) If the symptom continues when you connect the system to the wall outlet of another room, the problem is power noise.
- 3) If no problem has been found in the above “1) and 2)”, FE Board trouble is expected.

7.5.4 PW Doppler Mode Trouble

FE Board or BE Board trouble is expected.

- 1) If BW Mode is normal, BE Board trouble is expected.
- 2) If BW Mode has a problem, FE Board trouble is expected.

7.5.5 CW Doppler Mode Trouble

FE Board or BE Board trouble is expected.

- 1) If PW Doppler Mode is normal, CW Board trouble is expected.
- 2) If PW Doppler Mode has a problem, FE Board trouble is expected.

7.5.6 Color Doppler Mode Trouble

FE Board or BE Board trouble is expected.

- 1) If BW Mode is normal, BE Board trouble is expected.
- 2) If BW Mode has a problem, FE Board trouble is expected.

7.5.7 Motion Mode Trouble

FE Board or BE Board trouble is expected.

- 1) If BW Mode is normal, BE Board trouble is expected.
- 2) If BW Mode has a problem, FE Board trouble is expected.

8 Disassembly and Reassembly

8.1 Overview

Chapter 8 describes how to disassemble SONOACE X6.

Refer to this chapter when you upgrade or repair the hardware.

WARNING The system contains dangerous high voltage. Never disassemble the system. There is a risk of electric shock and injury.



The repair of the system and the replacement of parts must be carried out by an authorized engineer or the customer service department of MEDISON Co., Ltd.

The company is not responsible for any injury and damage caused by not following this warning.

WARNING When working with the system on, do not wear a static electricity protective wristband. There is a risk of electric shock and injury.



NOTE When disassembling or reassembling the system, wear static electricity protective gloves and a wristband.

These will prevent any accidents due to carelessness, and damage to the system due to static electricity.



[Figure 8-1] Static Electricity Protective Gloves and Wristband

Contents Disassembly and Reassembly

8.1	Overview	8-1
8.2	Disassembly and Reassembly of the External Case	8-4
8.2.1	Preparations	8-4
8.2.2	Cover Front Lower	8-4
8.2.3	Cover Top Plate	8-5
8.2.4	Cover Rear Lower	8-6
8.3	Disassembly and Reassembly of the LCD Monitor	8-7
8.3.1	Preparations	8-7
8.3.2	LCD Monitor	8-7
8.3.3	LCD Monitor Arm	8-8
8.4	Disassembly and Reassembly of the Ultrasound System PCB Part	8-9
8.4.1	Preparations	8-9
8.4.2	PSA ASSY	8-9
8.4.3	CW Board, FE Board, BE Board	8-10
8.4.4	DC to DC Power Module	8-11
8.5	Disassembly and Reassembly of the HDD & DVD	8-12
8.5.1	Preparations	8-12
8.5.2	HDD & DVD	8-12
8.6	Disassembly and Reassembly of the Rear Panel	8-13
8.6.1	Preparations	8-13
8.6.2	Rear Right Board & Rear Left Board	8-13
8.6.3	Back Fan	8-14
8.7	Disassembly and Reassembly of the Power Supply	8-16
8.7.1	Preparations	8-16
8.7.2	AC to DC Power Module	8-16
8.7.3	DC to DC Power Module	8-16
8.8	Disassembly and Reassembly of the Control Panel	8-17
8.8.1	Preparations	8-17
8.8.2	Control Panel	8-17
8.8.3	Key Matrix Board	8-18
8.8.4	Track Ball	8-19
8.8.5	Alpha Numeric Keyboard	8-20
8.8.6	Speaker	8-20

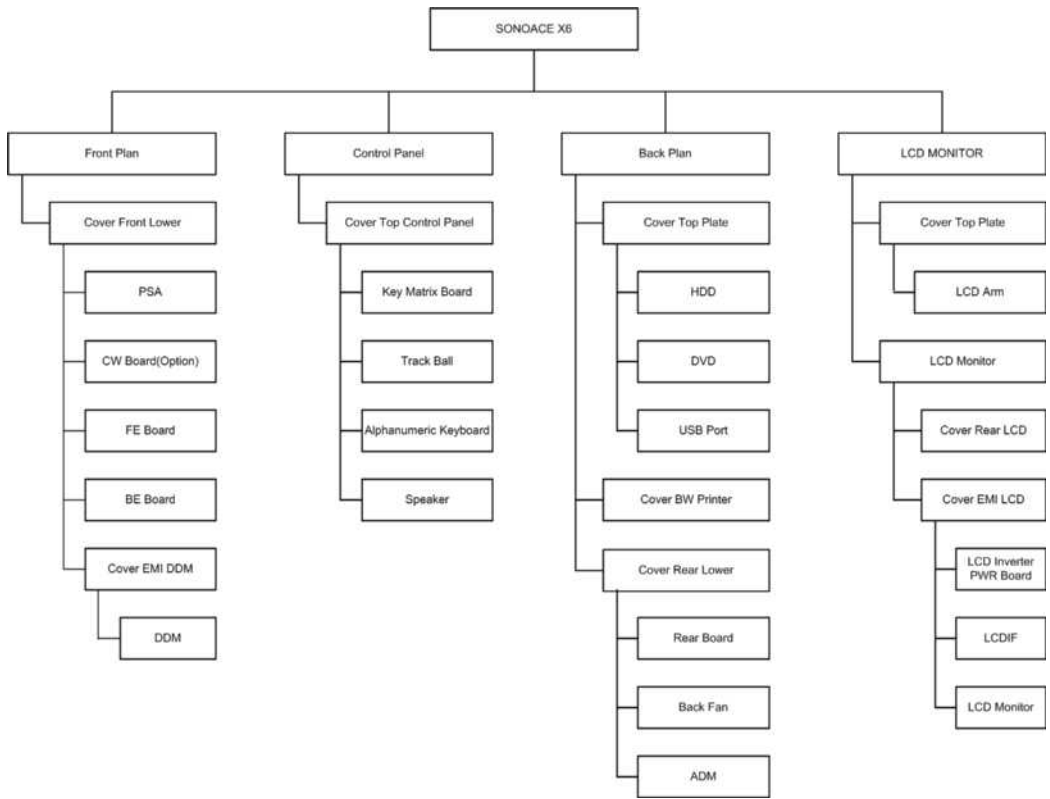

[Figure 8-2] Disassembly sequence flow chart

8.2 Disassembly and Reassembly of the External Case

8.2.1 Preparations

Prepare a (+) screwdriver and static electricity protective gloves.

Shut down the system referring to “3.7 System Shutdown (Power Shut Down)”

8.2.2 Cover Front Lower

1) Remove the 2 screws of the Cover Front Lower using the (+) screwdriver.

2) Hold and pull the lower part of the Cover Front Lower to separate it.

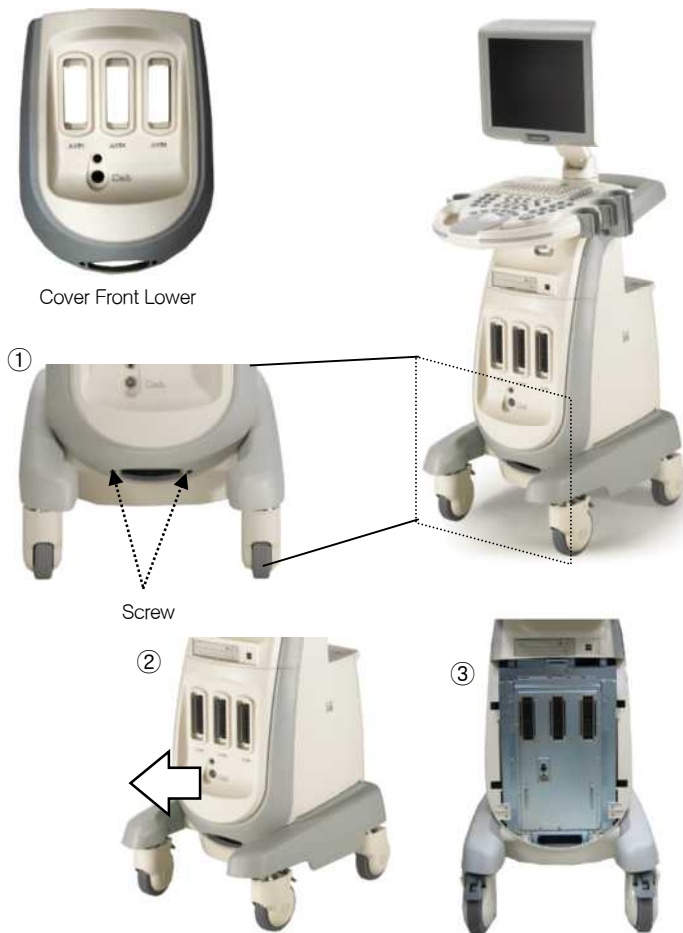

[Figure 8-3] Cover Front Lower

8.2.3 Cover Top Plate

- 1) Remove the 6 screws of the Cover Top Plate using the (+) screwdriver.
- 2) Hold and lift the Cover Top Plate to separate it.

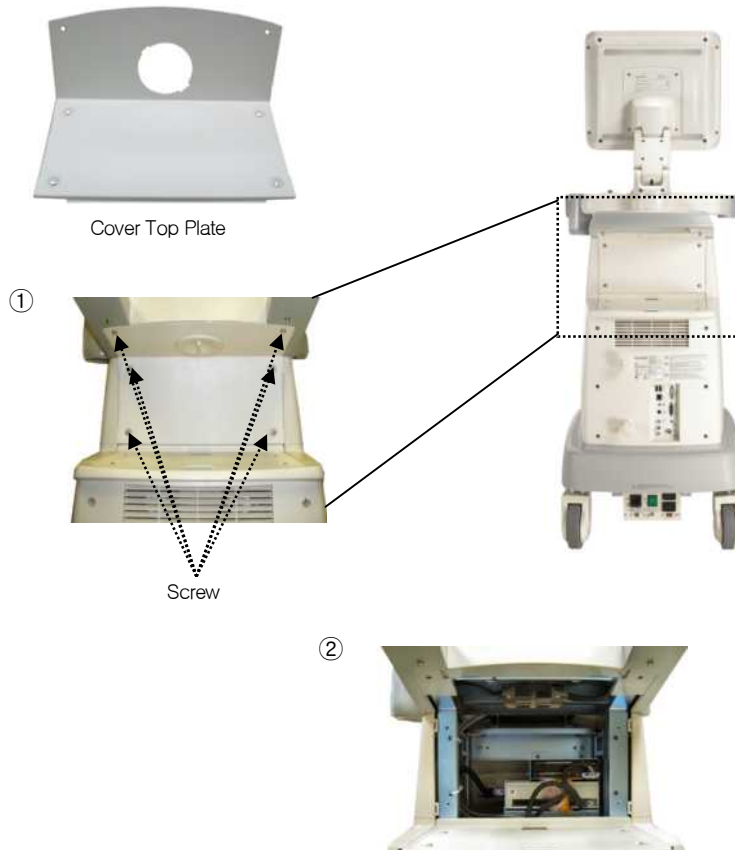

[Figure 8-4] Cover Top Plate

8.2.4 Cover Rear Lower

- 1) Remove the 6 screws of the Cover Rear Lower using the (+) screwdriver.
- 2) Hold and lift the upper part of the Cover Rear Lower to separate it.

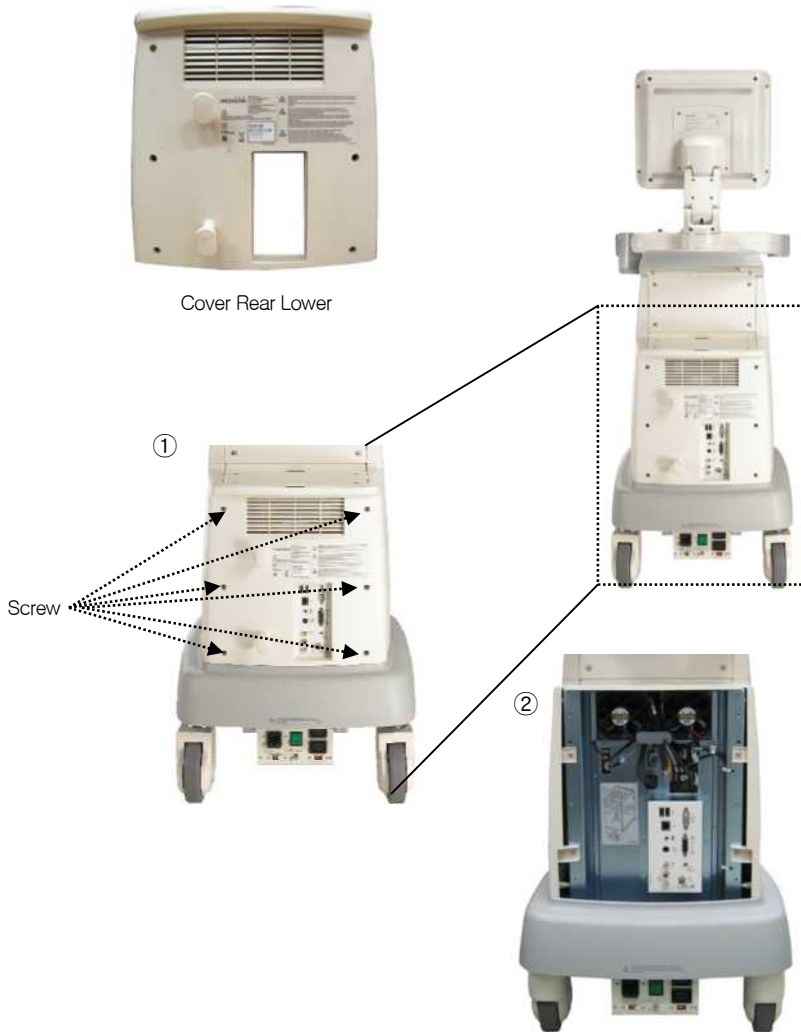

[Figure 8-5] Cover Rear Lower

8.3 Disassembly and Reassembly of the LCD Monitor

8.3.1 Preparations

Prepare a (+) screwdriver and static electricity protective gloves.

Prepare an LCD Monitor Panel protective cover.

Shut down the system referring to “3.7 System Shutdown (Power Shut Down)”

8.3.2 LCD Monitor

- 1) Remove the 4 screws from the Cover Bracket LCD using the (+) screwdriver and separate it.
- 2) Remove the 8 screws from the Cover Rear LCD using the (+) screwdriver.
- 3) Remove the 2 fixed screws of the DVI Cable using the (+) screwdriver and separate it.
- 4) Remove the 2 screws from the LCD Arm using the (+) screwdriver.
- 5) Hold the LCD Panel with both hands and disassemble it.

WARNING



- Although there is a catch to secure the LCD Panel, it may come off and fall, which will damage it.
- When disassembling or assembling the LCD Monitor, it is recommended to do it with another person.

- 6) Remove the 4 screws from the Cover EMI LCD using the (+) screwdriver and separate it.

- 7) Remove the 7 screws from the Cover EMI LCD and LCDIF Board using the (+) screwdriver and separate it.

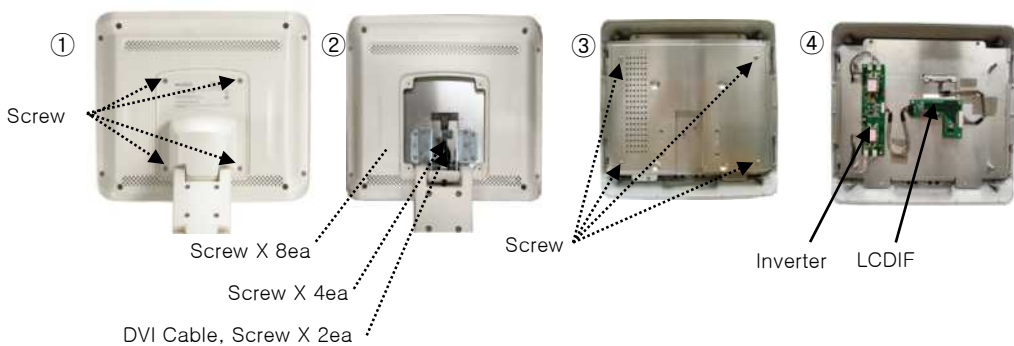

[Figure 8-6] LCD Monitor

8.3.3 LCD Monitor Arm

- 1) Disassemble the Cover Top Plate referring to “ 8.2.3 Cover Top Plate”.
- 2) Separate the DVI Cable connected to the LCD Monitor.
- 3) Remove the 2 screws from the Cover Swivel Rear using the (+) screwdriver and separate it.
- 4) Remove the 3 screws from the Cover Swivel Front using the (+) screwdriver and separate it.
- 5) Remove the 4 fixed screws of the LCD Monitor Arm using the (+) screwdriver.
- 6) Hold the LCD Monitor Arm with both hands and lift up

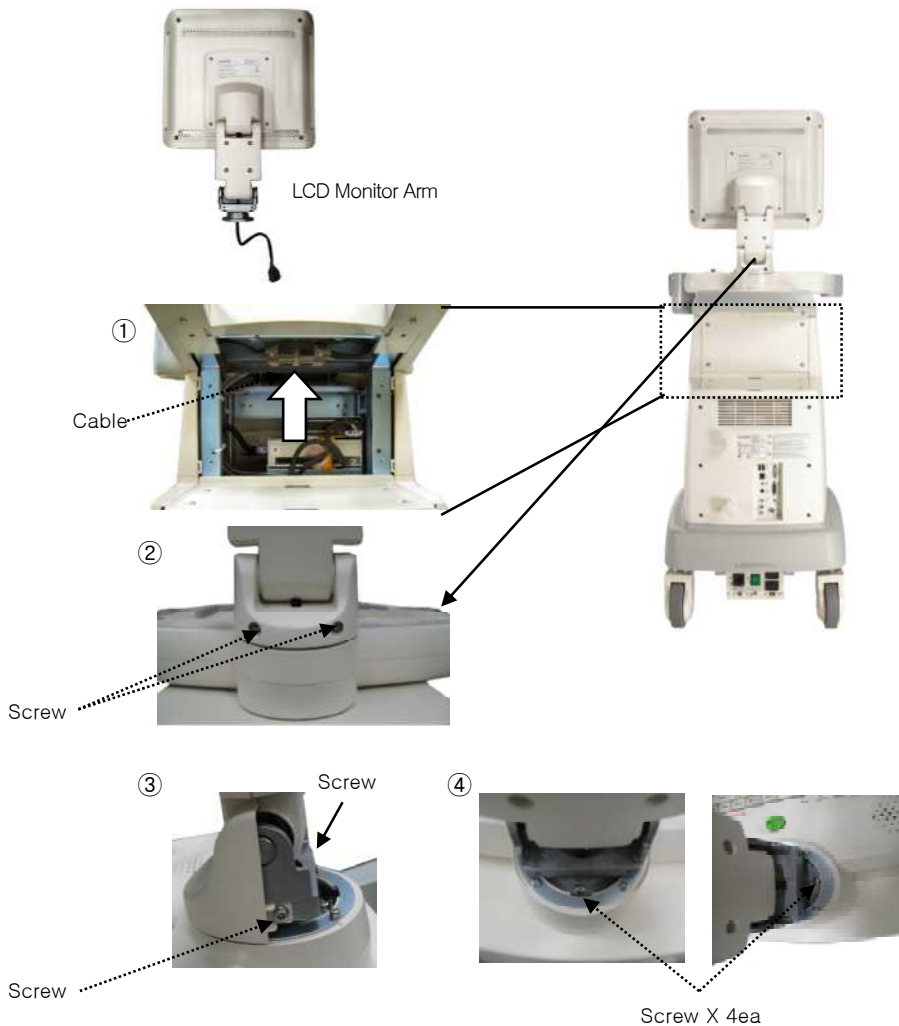

[Figure 8-7] LCD Monitor Arm

8.4 Disassembly and Reassembly of the Ultrasound System PCB Part

8.4.1 Preparations

Prepare a (+) screwdriver and static electricity protective gloves.

Shut down the system referring to "3.7 System Shutdown (Power Shut Down)

8.4.2 PSA ASSY

1) Disassemble the Cover Front Lower referring to "8.2.2 Cover Front Lower".

2) Remove the 8 screws from the PSA ASSY using the (+) screwdriver.

3) Hold the PSA ASSY with both hands and pull it to disassemble it.

WARNING



Since the edge of the PSA ASSY is sharp, disassemble it with care.



PSA ASSY

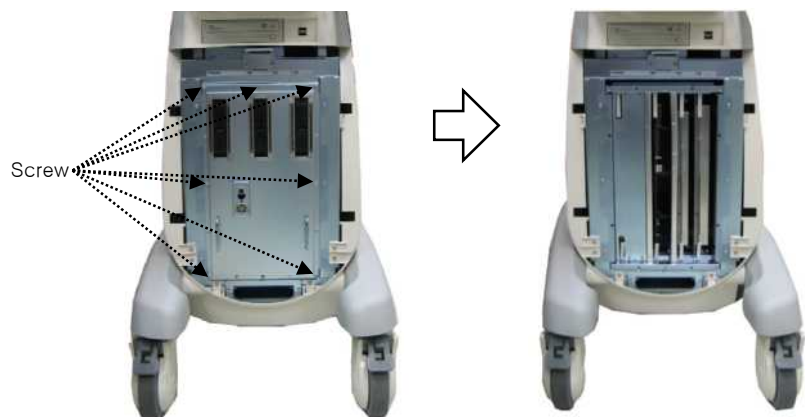

[Figure 8-8] PSA ASSY

8.4.3 CW Board, FE Board, BE Board

- 1) Disassemble the Cover Front Lower referring to "8.2.2 Cover Front Lower".
- 2) Disassemble the PSA ASSY referring to "8.4.2 PSA ASSY".
- 3) Hold the handle of the CW Board with both hands and pull it to separate it.
- 4) Hold the handle of the FE Board with both hands and pull it to separate it.
- 5) Hold the handle of the BE Board with both hands and pull it to separate it.

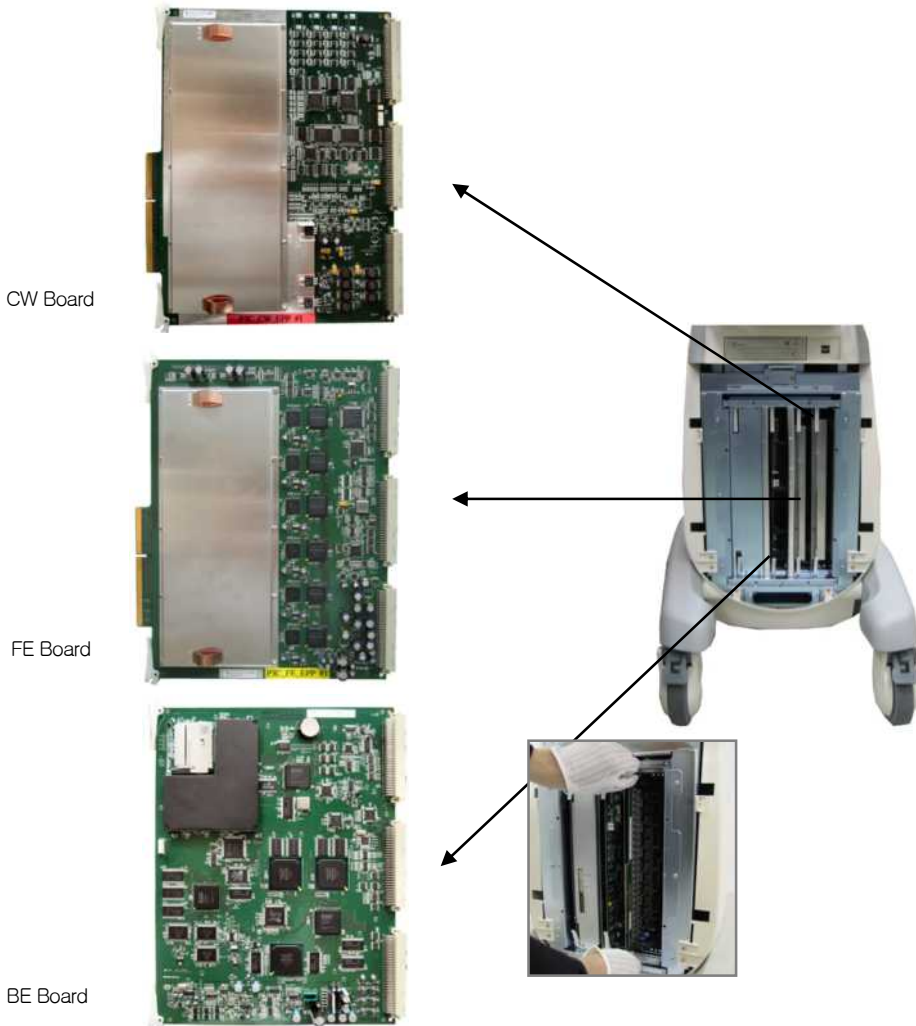

[Figure 8-9] CW Board, FE Board, BE Board

8.4.4 DC to DC Power Module

- 1) Disassemble the Cover Front Lower referring to "8.2.2 Cover Front Lower".
- 2) Disassemble the PSA ASSY referring to "8.4.2 PSA ASSY".
- 3) Remove the 4 screws from the DDM Cover using the (+) screwdriver and separate it.
- 4) Hold the handle of the DDM with both hands and pull it to separate it.

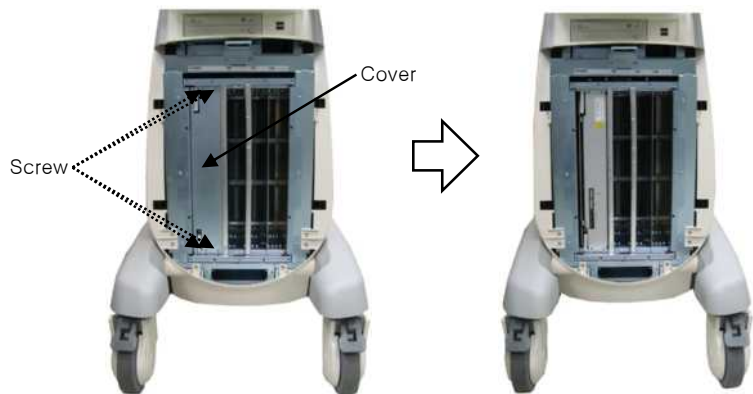

[Figure 8-10] DDM

8.5 Disassembly and Reassembly of the HDD and DVD

8.5.1 Preparations

Prepare a (+) screwdriver and static electricity protective gloves.

Shut down the system referring to “3.7 System Shutdown (Power Shut Down)”

8.5.2 HDD & DVD

1) Disassemble the Cover Top Plate referring to “8.2.3 Cover Top Plate”.

2) Separate the IDE Data Cable and Power Cable.

3) Remove the 4 screws of the Bracket using the (+) screwdriver and separate it.

4) Separate the HDD and DVD from the Bracket.

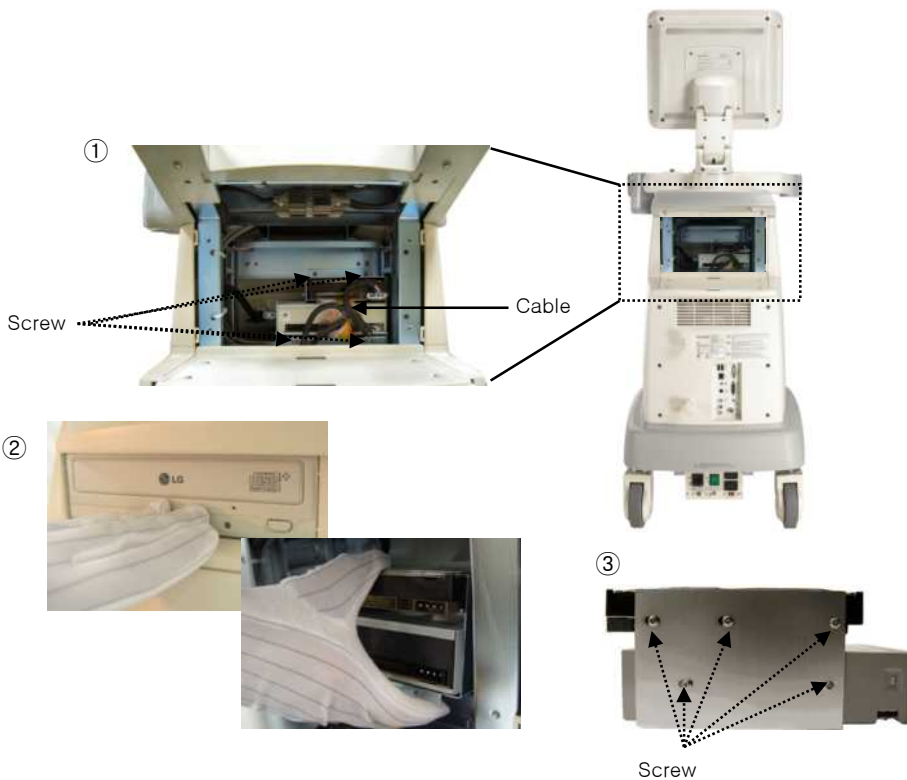

[Figure 8-11] HDD & DVD

8.6 Disassembly and Reassembly of the Rear Panel

8.6.1 Preparations

Prepare a (+) screwdriver and static electricity protective gloves.

Shut down the system referring to “3.7 System Shutdown (Power Shut Down)”.

8.6.2 Rear Right Board & Rear Left Board

1) Disassemble the Cover Rear Lower referring to “8.2.4 Cover Rear Lower”.

2) Remove the 6 screws of the Rear Panel ASSY using the (+) screwdriver and separate it.

3) Separate the Rear Right Board & Rear Left Board from the Bracket.

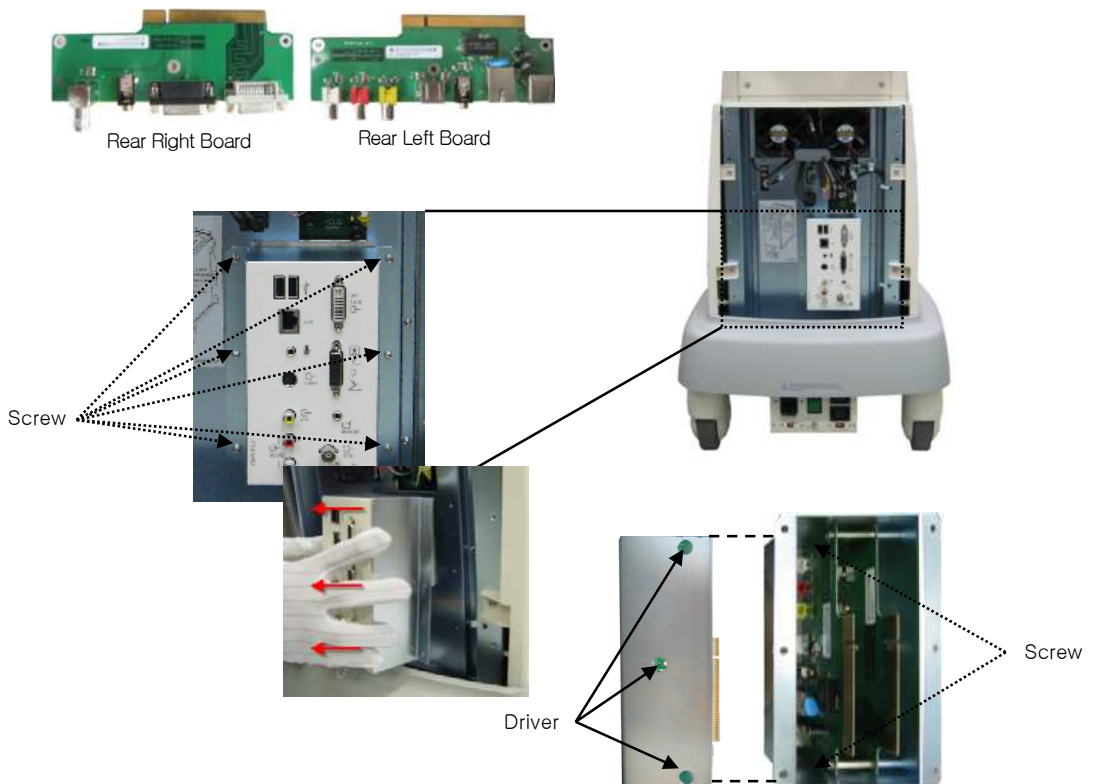

[Figure 8-12] Rear Right Board & Rear Left Board

8.6.3 Back Fan

- 1) Disassemble the Cover Rear Lower referring to "8.2.4 Cover Rear Lower".
- 2) Separate the cable connected to the mother board(J10).
- 3) Remove the 8 screws of the Back Fan using the (+) screwdriver and separate it.

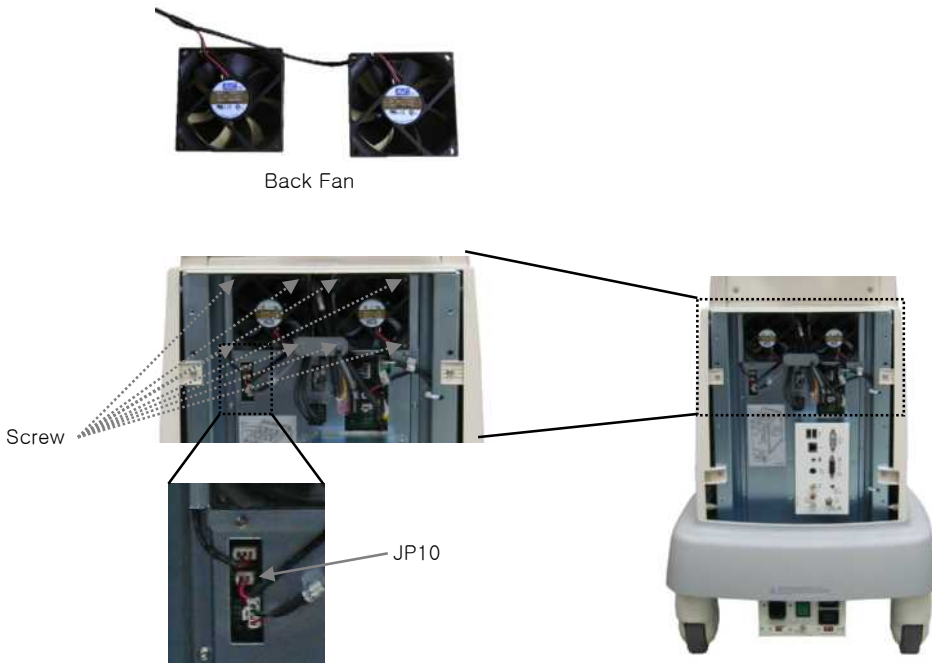

[Figure 8-13] Back Fan

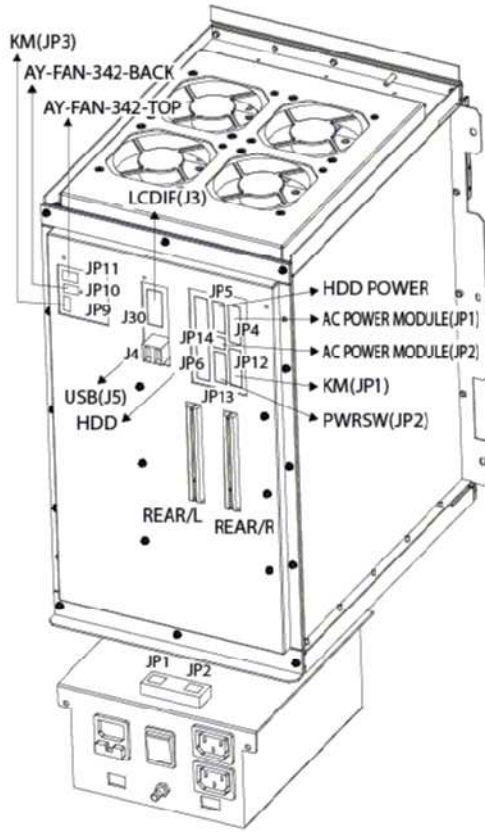

[Figure 8-14] Cable Connection of Back Plan

8.7 Disassembly and Reassembly of the Power Supply

8.7.1 Preparations

Prepare a (+) screwdriver and static electricity protective gloves.

Shut down the system referring to "3.7 System Shutdown (Power Shut Down)".

8.7.2 AC to DC Power Module

- 1) Disassemble the Cover Rear Lower referring to "8.2.4 Cover Rear Lower".
- 2) Remove the cable connected to the AC to DC Power Module.(JP1,JP2)
- 3) Remove the 2 screws of the AC to DC Power Module using the (+) screwdriver.
- 4) Hold the AC to DC Power Module and pull it to separate it.

WARNING Since the ADM is heavy, take care when disassembling it. If the ADM falls suddenly, it may cause an injury.

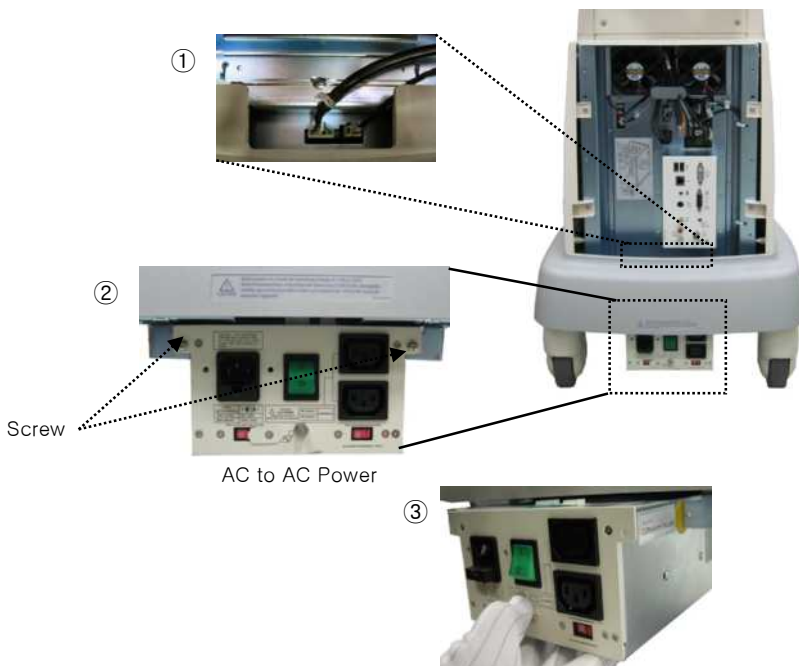

[Figure 8-15] AC to DC Power Module

8.7.3 DC to DC Power Module

Referring to "8.4.4 DC to DC Power Module".

8.8 Disassembly and Reassembly of the Control Panel

8.8.1 Preparations

Prepare a (+) screwdriver and static electricity protective gloves.

Shut down the system referring to "3.7 System Shutdown (Power Shut Down)"

8.8.2 Control Panel

1) Disassemble the LCD Monitor Arm referring to "8.3.3 LCD Monitor Arm ".

2) Remove the 4 screws for the Control Panel(Front Top) using the (+) screwdriver

3) Remove the 17 screws for the Control Panel(Bottom)using the (+) screwdriver

4) Separate the upper board of the Control Panel.

5) Separate the cable connected to the Control Panel Board and PWER SW Board.

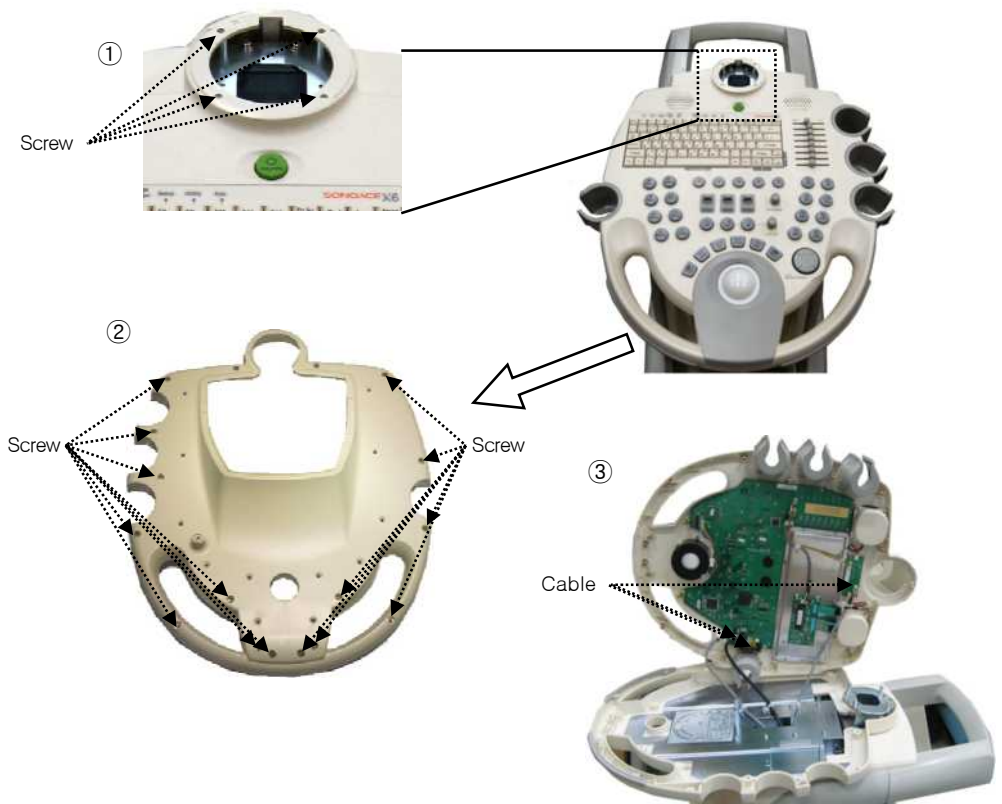

[Figure 8-16] Control Panel

8.8.3 Key Matrix Board

- 1) Disassemble the LCD Monitor Arm referring to "8.3.3 LCD Monitor Arm ".
- 2) Disassemble the Control Panel referring to "8.8.2 Control Panel ".
- 3) Separate all cables connected to the Key Matrix Board.
- 4) Take the TGC Cap off the Control Panel.
- 5) Remove all the screws of the Control Panel Board using the (+) screwdriver and separate it.

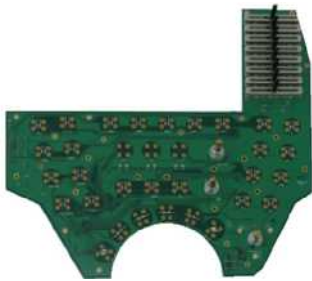

Control Panel Board



The 23 Screw

[Figure 8-17] Control Panel Board

8.8.4 Track Ball

- 1) Disassemble the LCD Monitor Arm referring to "8.3.3 LCD Monitor Arm".
- 2) Disassemble the Control Panel referring to "8.8.2 Control Panel".
- 3) Separate the cable connected to the Key Matrix Board.
- 4) Remove the 2 screws for the Trackball using the (+) screwdriver and separate it.



Track Ball

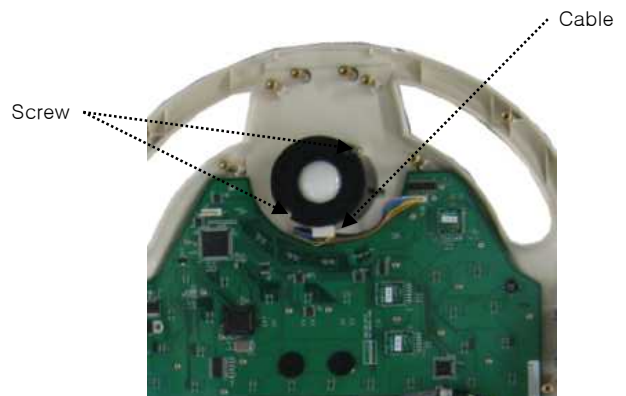

[Figure 8-18] Track Ball

8.8.5 Alpha-Numeric Keyboard

- 1) Disassemble the LCD Monitor Arm referring to "8.3.3 LCD Monitor Arm " .
- 2) Disassemble the Control Panel referring to "8.8.2 Control Panel " .
- 3) Separate the cable connected to the Alpha Numeric Keyboard.
- 4) Remove the 10 screws of the Alpha Numeric Keyboard using the (+) screwdriver and disassemble it.

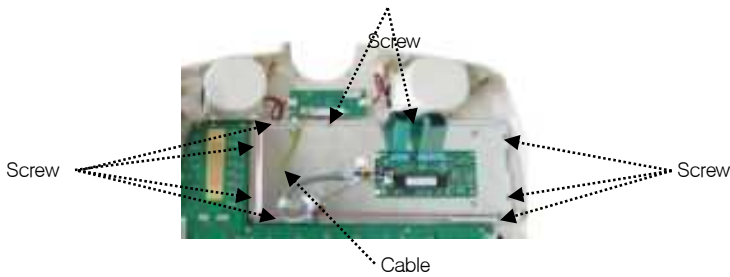

[Figure 8-19] Alpha Numeric Keyboard

8.8.6 Speaker

- 1) Disassemble the LCD Monitor Arm referring to "8.3.3 LCD Monitor Arm " .
- 2) Disassemble the Control Panel referring to "8.8.2 Control Panel " .
- 3) Separate the cable connected to the Speaker.
- 4) Remove the 8 screws fixed the Speaker using the (+) screwdriver.
- 5) Hold the Speaker and pull it to separate it.

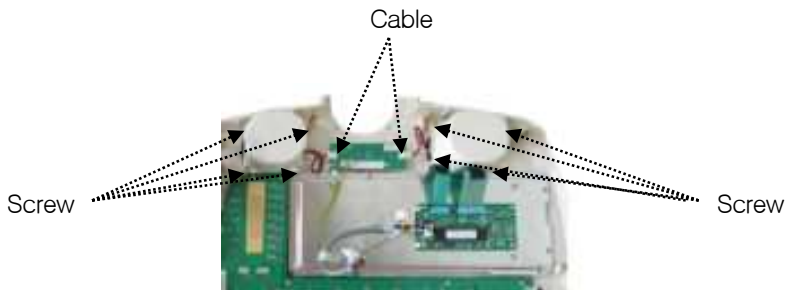

[Figure 8-20] Speaker

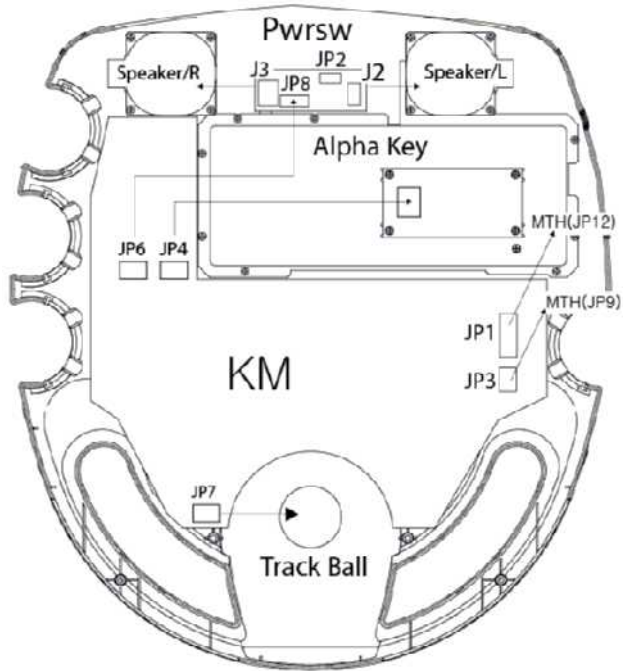

[Figure 8-21] Cable Connection of Control Panel

9 Probe

9.1 Overview

The probe is a device that sends and receives ultrasound for acquiring image data. It is also called a Transducer or Scanhead.

The system limits patient contact temperature to 43 C degrees Celsius, and acoustic output values to their respective U.S. FDA limits. A power protection fuse circuit protects against over-current conditions. If the power monitor protection circuit senses an over-current condition, then the drive current to the probe is shut off immediately, preventing overheating of the probe surfaces and limiting acoustic output. Validation of the power protection fuse circuit is performed under normal system operation. For invasive probes, additional protections are designed to keep patient contact surface temperature under 43 C degrees Celsius in the event of a single fault failure.

Contents Probe

9.1	Overview	9-1
9.2	Probe List	9-2
9.3	Thermal Index (TI Table)	9-3
9.4	Ultrasound Transmission Gel	9-4
9.5	Sheaths	9-5
9.6	Probe Precautions	9-6
9.7	Cleaning and Disinfecting the Probe	9-8

9.2 Probe List

The ultrasound image scanner uses probes to obtain graphic data of the human body and then displays it on the screen. Always use application-specific probes in order to obtain the best quality images. It is also important to configure the probe with the best settings for the particular organ being scanned.

9.2.1 Probe Application and Preset

Probes, applications and settings available for this product are as follows:

Probes	Applications
C3-7EP	General, OB, Gynecology, Abdomen, Fetal Heart, Renal
C4-9ED	General, Pediatric, Vascular, Neonatal
HL5-12ED	General, Breast, Small Parts, Vascular, Musculoskeletal
L5-12/50EP	General, Breast, Small Parts, Vascular, Musculoskeletal
NER4-9ES	General, OB, Gynecology, Urology
NEV4-9ES	General, OB, Gynecology, Urology
P2-4AH	General, Abdomen, Cardiac, Pediatric, TCD
CW2.0	General, Cardiac
CW4.0	General, Pediatric, Cardiac

9.3 Thermal Index (TI) Tables

TI(TI;Thermal Index) values displayed on the screen title bar can change depending on probes and applications. ACCUVIX V20 decides automatically which TI value will be displayed out of TIs(TI;Thermal Index System), Tlb(TI;Thermal Index Bone), and Tlc(TI;Thermal Index Cranium). The TI values are as follows,

Probes	Applications															
	General	Obstetrics	OB Early	Gynecology	Abdomen	Fetal Heart	Cardiac	Breast	Vascular	Urology	Renal	Small Parts	Neonatal	Pediatric	TCD	Musculoskeletal
C3-7EP	TIs	Tlb	TIs	TIs	TIs	Tlb					TIs					
C4-9ED	TIs								TIs				Tlc	TIs		
HL5-12ED	TIs							TIs	TIs			TIs				TIs
L5-12/50EP	TIs							TIs	TIs			TIs				TIs
NER4-9ES	TIs	Tlb		TIs						TIs						
NEV4-9ES	TIs	Tlb		TIs						TIs						
P2-4AH	TIs				TIs		TIs							TIs	TIs	
CW 2.0	TIs						TIs									
CW 4.0	TIs						TIs							TIs		

9.4 Ultrasound Transmission Gel

Using an inappropriate ultrasound gel may damage the probe. For proper transmission of the acoustic beam, only use ultrasound transmission gel only approved by MEDISON.

WARNING



- Do not use mineral oil, oil-based solutions, or other non-approved material as they may cause damage to the probe.
- Do not use gels that contain any of the following agents:
 - Acetone
 - Methanol
 - Denatured Ethyl Alcohol
 - Mineral Oil
 - Iodine
 - Lanolin
 - Any lotions or gels containing perfume

9.5 Sheaths

Sheaths are recommended for clinical applications of an invasive nature, including intraoperative, transrectal, transvaginal, and biopsy procedures.

MEDISON does not supply sheaths so that you should purchase appropriate ones on your own.

9.5.1 Install the Sheaths

- 1) Put on sterile gloves. Unpack the sheath and fill it with acoustic coupling gel.
- 2) Insert the probe into the sheath and pull the latex tip to cover the probe completely. If possible, cover the probe cable as well.
- 3) Ensure that there is no air bubble in the ultrasound gel. If necessary, secure the sheath to the probe and the probe cable.
- 4) Dispose of the sheath after use.

WARNING



- Always keep sheaths in a sterile state.
- Sheaths are disposable. Do not reuse them.
- If sheaths are torn or soiled after use, clean and disinfect the probe.
- In neurosurgical applications, a disinfected probe must be used with sterile gel and a sterile pyrogen-free sheath.
- If the sterile sheath becomes compromised during neurosurgical applications involving a patient with Creutzfeldt-Jakob disease, the probe cannot be successfully sterilized by any disinfection method.
- Some sheaths contain natural rubber latex and talc, which can cause allergic reactions in some individuals. Please refer to the FDA Medical Alert released on March 29, 1991.

9.6 Probe Precautions

The probe can easily be damaged by improper use or by contacting certain chemical substances. Always follow the instructions in the user manual to inspect the probe cable, case and lens before and after each use.

Check for cracks, broken parts, leaks and sharp edges. If there is any damage, immediately stop using the probe and contact the MEDISON Customer Support Department. Using damaged probes may result in electric shocks and other hazards to the patients and/or users.

CAUTION



- Do not apply mechanical shock to the probe.
- Do not place the probe cable on the floor where the cable can be run over by equipment wheels, etc. Do not apply excessive force to bend or pull the cable.
- Do not immerse the probe into any inappropriate substances such as alcohol, bleach, ammonium chloride, and hydrogen peroxide.
- Do not expose the probe to temperatures of 50 C or higher.

9.6.1 Use and Infection Control of the Probe

The ultrasonographic image scanner uses ultrasound, and it makes direct contact with the patient when in use. Depending on the types of examinations, such contact can be made to a wide variety of locations including the ordinary skin or the location of blood transfusion during a surgery.

The most effective method to prevent infection among patients is to use each probe only once. However, probes may need to be reused, as they are complex in design and expensive. Consequently, protective devices such as sheaths must be used, and the safety instructions must be followed carefully in order to minimize the risk of infection among patients.

WARNING



No neurosurgical treatments or examinations should be carried out on a patient with Creutzfeldt–Jakob disease (critical brain disease caused by virus). If the probe has been used on such a patient, it cannot be sterilized by any method whatsoever.

CAUTION

Sufficient washing and disinfecting must be carried out for preventing infection. This is the responsibility of the user who manages and maintains the disinfection procedures for the equipment. Always use legally approved detergents and sheaths.

9.6.2 Electric Shocks

The probe uses electrical energy. If it touches conductive materials, there are risks of electric shocks to the patient or the user

WARNING

- Regularly receive short-circuit examination from the MEDISON Customer Service Department.
- Do not immerse the probe into liquid.
- Do not drop the probe or apply mechanical shocks.
- Inspect the housing, strain relief, lens and seal for damage, and check for any functional problem before and after each use.
- Do not apply excessive force to twist, pull or bend the probe cable. It may result in a short circuit.
- The power protection fuse protects the probe and the product from excess current. If the power monitoring protection circuit detects excess current, it immediately shuts off the current to the probe in order to prevent the probe surface from overheating and to restrict the ultrasound power output.
- The temperature of the product for making contact with patients is limited under 43°C. The ultrasound power output (AP&I) is in compliance with US FDA standards.

9.7 Cleaning and Disinfecting the Probe

Using an inappropriate detergent or disinfectant may damage the probe.

WARNING Always use protective eyewear and gloves when cleaning and disinfecting probes.

9.7.1 Information of Detergent, Disinfectant, and Ultrasound Gel

Use an appropriate one with following tables. The information is also listed on the Medison web site. (<http://www.medison.com>)

Names		Disinfectants									
		T-Spray II	T-Spray	Sani-Cloth	Cidex OPA ^{2,3)}	Cidex Plus ²⁾	Metricide ²⁾	Omnicide	Nuclear	Wavicide-01 ³⁾	Sekusept Extra
Type		Spray		Wipe	Liquid						
Active Ingredient		Quaternary Ammonium (N-Alkyl)			Glutaraldehyde						
CA	C3-7EP		●	●	●	●					
	C4-9ED		●	●	●	●		●	●	●	
LA	HL5-12ED		●	●	●	●		●	x	●	
	L5-12/50EP		●	●	●	●				●	
EC	NER4-9ES		●	●							
	NEV4-9ES		●	●							
PA	P2-4AH	●		●	●	●				●	
CW	CW2.0	●	●	●	★	●				●	
	CW4.0										

Names		Disinfectants			Cleaner				Gel
		Sporox II	Gigasept AF ³⁾	Gigasept FF	Enzol	Klenzyme	Isopropyl alcohol (70%)	Metrizyme	Aquasonics 100 ³⁾
Type		Liquid			NA	Liquid		Gel	
Active Ingredient		Hydrogen Peroxide	Succindialdehyde, formaldehyde	Bersteins-aure	Proteolytic Enzymes	Alcohol	Propylene Glycol	Proteolytic Enzymes	
CA	C3-7EP	x			●	●		●	●
	C4-9ED	x			●	●	x	●	●
LA	HL5-12ED	x			●	●	x	●	●
	L5-12/50EP	x			●	●	x	●	●
EC	NER4-9ES								
	NEV4-9ES								
PA	P2-4AH	●			●	●		●	
CW	CW2.0	x	x	●	●	●	x	●	●
	CW4.0								

NOTE

x = Not compatible(DO NOT USE)

● = Compatible

Blank = Untested (DO NOT USE)

★ = Staining may occur on housing parts; however, the acoustic performance and image quality are not affected.

- 1) Compatible but no EPA Registration
- 2) FDA 510(k) qualified
- 3) Has CE mark
- 4) Discontinued
- 5) Under Development

Following is information about manufacturer (or Distributor) of Detergent, Disinfectant, and Ultrasound Gel.

Product	Manufacturer or Distributor	Telephone number
Aquasonics	Parker Co.	+1-800-631-8888(USA)
Cidex	CIVCO Co.	+1-800-445-6741(USA) +1-319-656-4447(Worldwide)
Enzol	CIVCO Co.	+1-800-445-6741(USA) +1-319-656-4447(Worldwide)
Glgasept AF	S&M(Schulke&mayr) Co.	+44-114-254-3500(UK)
Gigasept FF	S&M(Schulke&mayr) Co.	+44-114-254-3500(UK)
Isopropyl alcohol (70%)	Local drugstore	None
Klenzyme	Steris Co.	+1-800-548-4873(USA)
Metricide	CIVCO Co.	+1-800-445-6741(USA) +1-319-656-4447(Worldwide)
Metrizyme	Metrex Research Corp.	+1-800-841-1428(USA)
Milton	Product & Gamble Australia Pty. Ltd.	+61-1800-028-280(Australia)
Nuclear	Nation Diagonostics Co.	+1-800-526-3867(USA) +44(0)-148-264-6020(UK)
Omnicide	Cottrell Ltd.	+1-800-THE-EDGE(USA)
Sani-cloth	PDI Nice/Pak Products Co.	+1-914-365-1602(USA)
Sekusept Extra	Henkel Hygiene GmbH.	+49-0211-797-0(Germany)
Sporox II	Sultan Chemist Inc.	+1-800-637-8582(USA)
T-Spray	CIVCO Co.	+1-800-445-6741(USA) +1-319-656-4447(Worldwide)
Virkon	Antec International LTD.	+1-403-286-1771(USA)
Wavicide	Wave Energy System Inc.	+1-800-252-1125(USA)

9.7.2 Cleaning

Cleaning is an important procedure that is carried out before disinfecting the probe. The probe must be cleaned after each use.

CAUTION



- Do not use a surgical brush when cleaning probes. The use of even soft brushes can damage the probe.
- During cleaning and disinfection, keep the parts of the probe that must remain dry higher than the other parts during wetting until all parts are dry. This will help prevent liquid from entering non-liquid-tight areas of the probe.

- 1) Disconnect the probe from the system.
- 2) Remove any biopsy adapters or biopsy needle guides. (Biopsy adapters are reusable and can be disinfected).
- 3) Discard sheaths. (Sheaths are single-use items).
- 4) Use a soft cloth lightly dampened with mild soap or compatible cleaning solution to remove any particulate matter and body fluid that remain on the probe or cable.
- 5) To remove remaining particulates, rinse with water up to the immersion point.
- 6) Wipe with a dry cloth.
- 7) If necessary, wipe first with a water-dampened cloth to remove soap residue.

9.7.3 Disinfection

WARNING



- If a pre-mixed solution is used, be sure to observe the solution expiration date.
- The type of tissue it will contact during use dictates the level of disinfection required for a device. Ensure that the solution strength and duration of contact are appropriate for disinfection.

CAUTION



- Using a non-recommended disinfectant or not following the recommended disinfection method can damage and/or discolor the probe and will void the probe warranty.
- Do not immerse probes for longer than one hour, unless they are sterilizable.
- Only sterilize probes using liquid solutions. Avoid using autoclave, gas (EtO), or other non-MEDISON-approved methods.

- 1) Follow the instructions on the disinfectant label for storage, use and disposition of the disinfectant.
- 2) Mix the disinfectant compatible with your probe according to level instructions for solution strength.
- 3) Immerse the probe into the disinfectant as shown in the illustration below.
- 4) Using the instructions on the disinfectant, rinse the probe after the immersion process is complete.
- 5) Air dry the probe or towel it dry with a clean cloth.

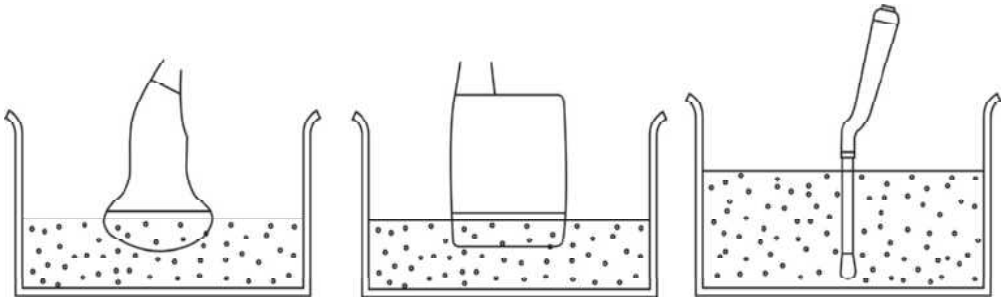

[Figure 9-1] Disinfection

10 User Maintenance

10.1 Overview

Chapter 10 describes how to extend the life of SONOACE X6.

It includes are how to maintain the product and how to backup information.

Make sure to read this chapter for proper maintenance of the product.

Contents User Maintenance

10.1	Overview	10-1
10.2	System Maintenance	10-2
10.2.1	Installation Maintenance	10-2
10.2.2	Cleaning and Disinfections	10-3
10.2.3	Fuse Replacement	10-5
10.2.4	Cleaning the Air Filter	10-6
10.2.5	Accuracy Check	10-6
10.3	Administration of Information	10-7
10.3.1	User Setting Back-up	10-7
10.3.2	Patient Information Back-up	10-7
10.3.3	Software	10-7

10.2 System Maintenance

10.2.1 Installation Requirements

When installing:

- Avoid humidity.
- Avoid direct sunlight.
- Avoid places with extreme temperature variations.
- Optimal conditions for the system are temperatures of 10°C ~ 35°C and humidity of 30% ~ 75%.
- Avoid heat sources.
- Avoid dusty and unventilated areas.
- Avoid places where the system is likely to be exposed to vibration or impacts.
- Avoid places where the system is likely to be exposed to chemical substances or gases.

NOTE The user must ensure that the safety inspections are performed every two years according to the requirements of safety standard EN 60601-1. Only trained persons are allowed to perform the safety inspections mentioned above.

CAUTION  Placing the system near generators, X-Ray machines, or broadcast cables may result in screen noise and abnormal visual images. Using the power source with other electric devices may also induce noise.

10.2.2 Cleaning and disinfections

Using inappropriate detergent or disinfectant may damage the product. Please read the following carefully.

WARNING



- Turn off the system and disconnect the system power cord from the wall outlet. Otherwise, it may result in electric shock or fire.
- Always use protective eyewear and gloves when cleaning and disinfecting the equipment.

10.2.2.1 Cleaning

- 1) Console : Use a soft cloth lightly dampened in a mild soap or detergent solution to clean exterior surfaces on the system
- 2) Cleaning Monitor : Wipe the LCD surface with a soft dry cloth. When the LCD panel has dirt on it, wipe it 2 – 3 times or more in one direction system.

CAUTION



- Do not use a spray directly on the product exterior. It may cause cracks in the appliance, or the color to deteriorate.
- Do not use chemical substances such as wax, benzene, alcohol, thinner, mosquito repellent, deodorant, lubricant or detergent.

NOTE

For information on cleaning and disinfection of the probe & biopsy kit, please refer to Chapter 8 "Probes." In User Manual

10.2.2.2 Disinfections

CAUTION



Use only recommended disinfectants on system surfaces.

A disinfectant qualified by the FDA 510(k) process is recommended. The following disinfectants are recommended because of both their biological effectiveness (as qualified through the FDA 510(k) process) and their chemical compatibility with MEDISON ultrasound products.

Solutions	Country	Type	Active ingredient	FDA 510(k)
Cidex	USA	Liquid	Gluteraldehyde	K934434
Cidex Plus	USA	Liquid	Gluteraldehyde	K923744

[Table 10–1] Solutions

- 1) Turn off the system and disconnect the system power cord from the wall outlet.
- 2) Mix the disinfection solution compatible with your system according to label instructions for solution strength.
- 3) Wipe the system surfaces with the disinfectant solution, following the disinfectant label instructions for wipe durations, solution strength, and disinfectant contact duration.
- 4) Air dry or towel dry with a sterile cloth according to the instructions on the disinfectant label.

10.2.3 Fuse Replacement

The power protection fuse protects the product from excess current. If the power monitoring protection circuit detects excess current, it shuts off the current to the equipment in order to prevent overheating and to restrict the ultrasound power output.

If the fuse blows, replace it as shown below.

DANGER To avoid risk of electric shock, always disconnect the plug from the system prior to fuse replacement.

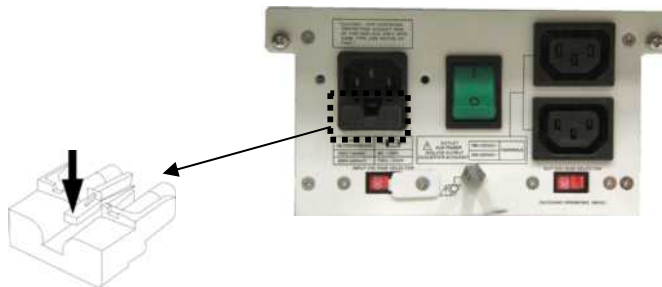

[Figure 10-1] Fuse replacement

- 1) Turn off the system and disconnect the system power cord from the wall outlet
- 2) Press the fuse holder in the direction of the arrow and pull it out.
- 3) Remove the old fuse and replace it with a new one.
- 4) After installing the new fuse, connect the plug to the system.

Input Ratings	Fuse Ratings	Maker	Order No.
100-120VAC	8AH/250V	Orisel	55T210000
200-240VAC	10A/H250V	Orisel	55T210000

[Table 10-1] Fuse Ratings

10.2.4 Cleaning the Air Filter

The air filters minimize the indraft of dust. Clean the air filter to ensure that a clogged filter does not cause the system to overheat and reduce the noise and the system performance.

It is recommended the air filters be cleaned once every three months.

CAUTION



Be sure to lock the brakes on the front wheels before cleaning the air filters to avoid injury by any unexpected movement of the product.

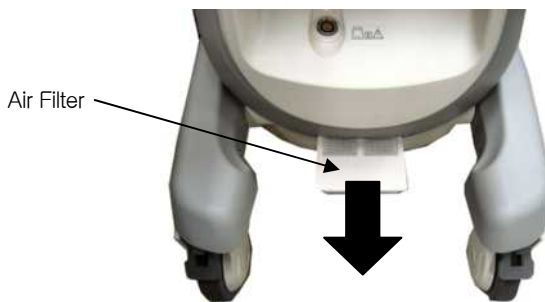

[Figure 10-2] The location of the air filters

- 1) Pull the filter under the front of the console to away from the product.
- 2) Shake the filter to remove the dust and wash in a mild soapy solution.
- 3) Rinse and air dry or dry with a cloth.
- 4) Slide the filter back into the product.

NOTE

Allow the wet filter to dry thoroughly before installing. The wet filter can cause the malfunction.

10.2.5 Accuracy Check

The product's maintenance status may affect the measurements obtained using the product. The product should be maintained in an optimal state to ensure reliable measurements.

To ensure optimal operation of the product, perform an accuracy check every year. The equations and table related to measurement accuracy are included in Chapter 5 "Measurements" in User manual.

10.3 Administration of Information

CAUTION You may lose information files on user settings or patients, because of shock on the product or internal error. Thus, back-up on a regular basis.



10.3.1 User Setting Back-up

Always keep a backup copy of all information related to the user settings in case of data loss. Clients cannot back-up the user settings of the product. Please contact the MEDISON Customer Service Department to attain support for back-up.

However, clients may back up the user setting on GA Table used in obstetrics diagnosis. For further information please refer to 'Chapter 3. Settings of User Manual'.

10.3.2 Patient Information Back-up

The SonoView program can be used for backing up patients' basic information and scanned images. The user can choose to save the data, and the data is also saved in the system by default. If the system needs to be reinstalled due to product failure, etc., the MEDISON customer support staff will restore the patients' basic information and scanned images that are saved in the system. For more information on this, see 'Chapter 6 Image Management of User Manual'.

10.3.3 Software

The product software may be updated to enhance performance. The user cannot make any changes to the software. Please contact the MEDISON customer service for help in software changes.

CAUTION Minor software updates may be carried out without the prior notice from the manufacturer.



Should errors occur in the operating system (Linux), and should you desire to upgrade the operating system, please follow the instructions of the operating system manufacturer.

11 Service Part List

11.1 Overview

This chapter 11 contains information on the SONOACE X6 Service Part.

Please refer to the SONOACE X6 Part Catalogue to Check the replacement parts and their software versions for each system configuration.

For installing and verifying system parts, please refer to figures and part table in this chapter.

Part numbers are indicated in the corresponding table.

Prior to ordering parts, please verify whether the existing parts can be replaced according to the current service policy

Contents Service Part List

11.1	Overview	11-1
11.2	Cover	11-2
11.3	Ultrasound System Part	11-4
11.4	Rear Plan	11-5
11.5	Power Part	11-6
11.6	LCD Monitor	11-7
11.7	Control Panel	11-9
11.8	Probe	11-10

11.2 Cover

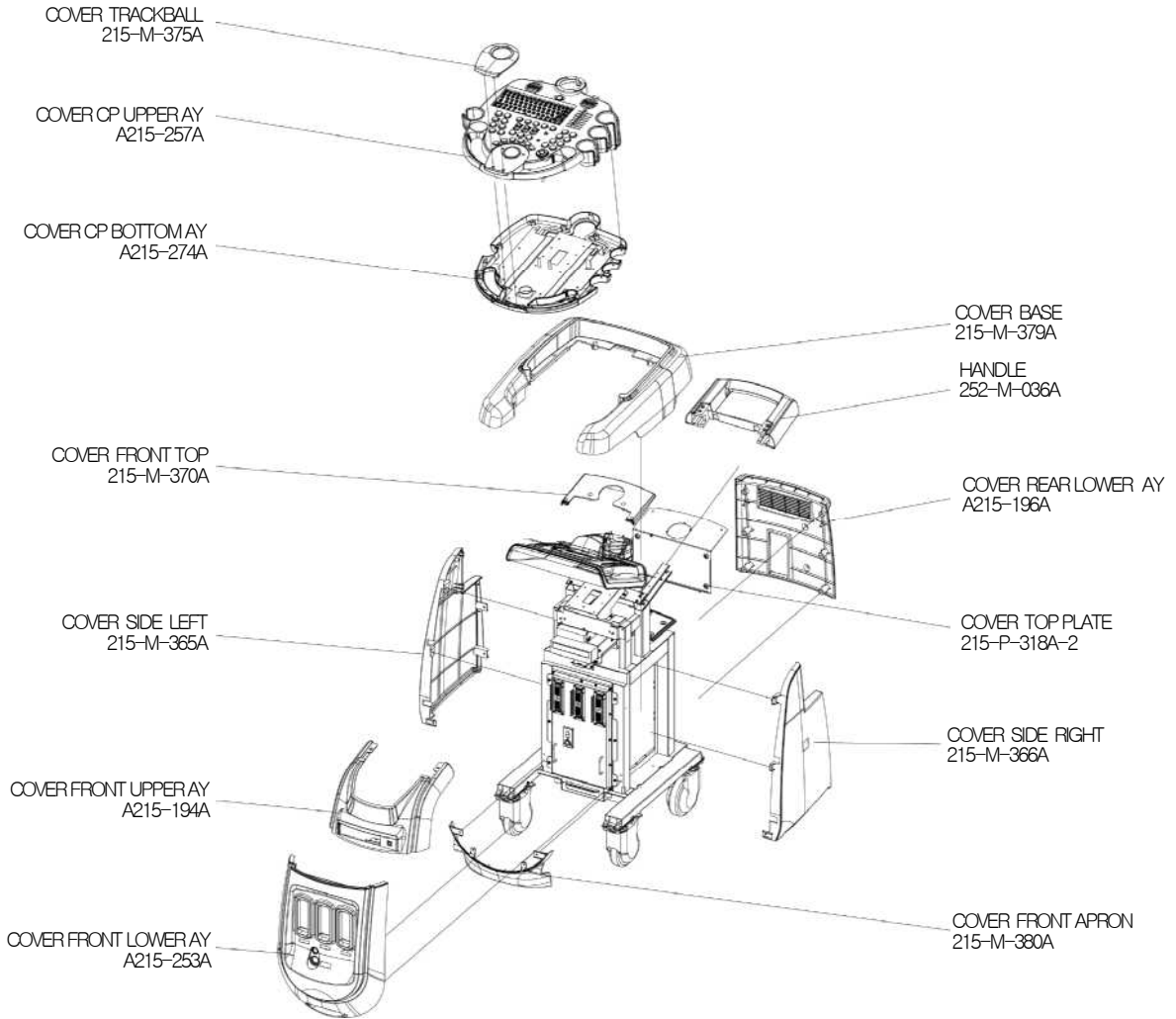

[Figure 11-1] SONOACE X6 Cover

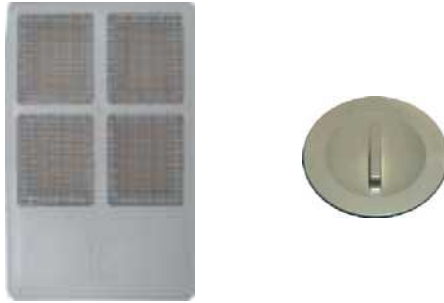

[Figure 11-2] Air Filter & Cover MNT Connector

PART NUMBER	DESCRIPTION
A215-274A	COVER CP BOTTOM AY X6
A215-257A	COVER CP UPPER AY X6
A215-253A	COVER FRONT LOWER AY X6
A215-196A	COVER REAR LOWER AY X4
A215-194A	COVER FRONT UPPER AY X4
215-P-318A-2	COVER TOP PLATE X4
252-M-036A	HANDLE X4
215-M-380A	COVER FRONT APRON X4
215-M-379A	COVER BASE X4
215-M-375A	COVER TRACKBALL X4
215-M-370A	COVER FRONT TOP X4
215-M-366A	COVER SIDE RIGHT X4
215-M-365A	COVER SIDE LEFT X4
325-M-002A	FILTER DUST X4
215-M-701A	COVER MNT CONNECTOR X4

[Table 11-1] SONOACE X6 Cover

11.3 Ultrasound System Part

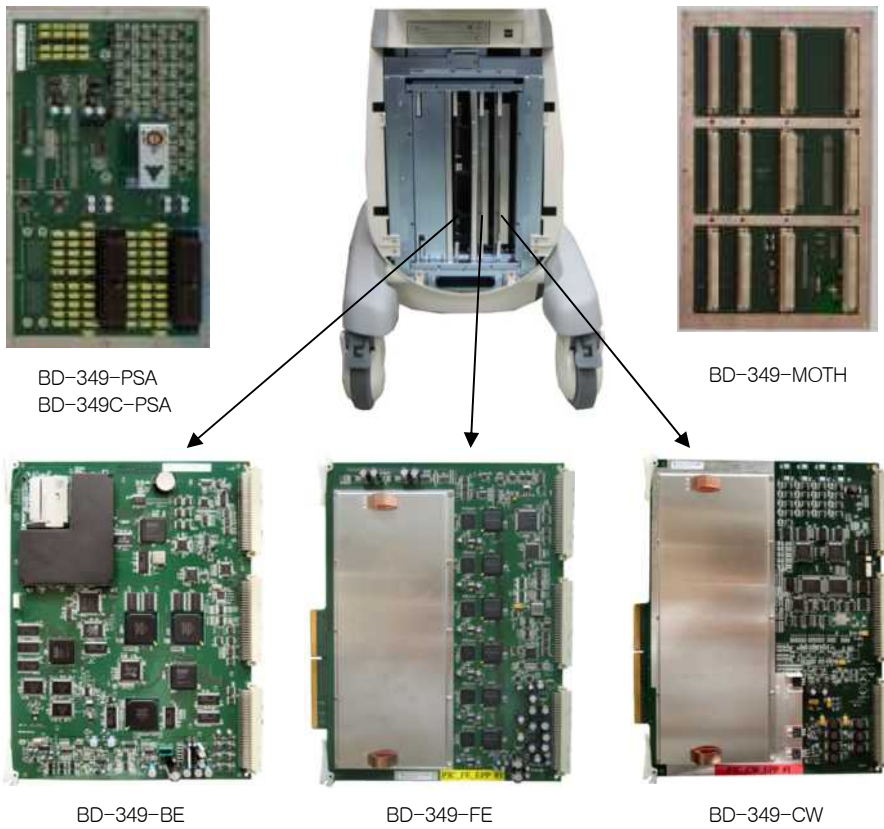

[Figure 11-3] Ultrasound System Part

PART NUMBER	DESCRIPTION
BD-349-PSA	PSA BD SONOACE X6
BD-349C-PSA	PSA BD SONOACE X6 (NON CW)
BD-349C-PSA-2P	PSA 2 PORT BD SONOACE X6 (NON CW)
BD-349-CW	CW BD SONOACE X6
BD-349-FE	FE BD SONOACE X6
BD-349-BE	BE BD SONOACE X6
BD-349-MOTH	MOTHER BD SONOACE X6

[Table 11-2] Ultrasound System Part

11.4 Rear Plan

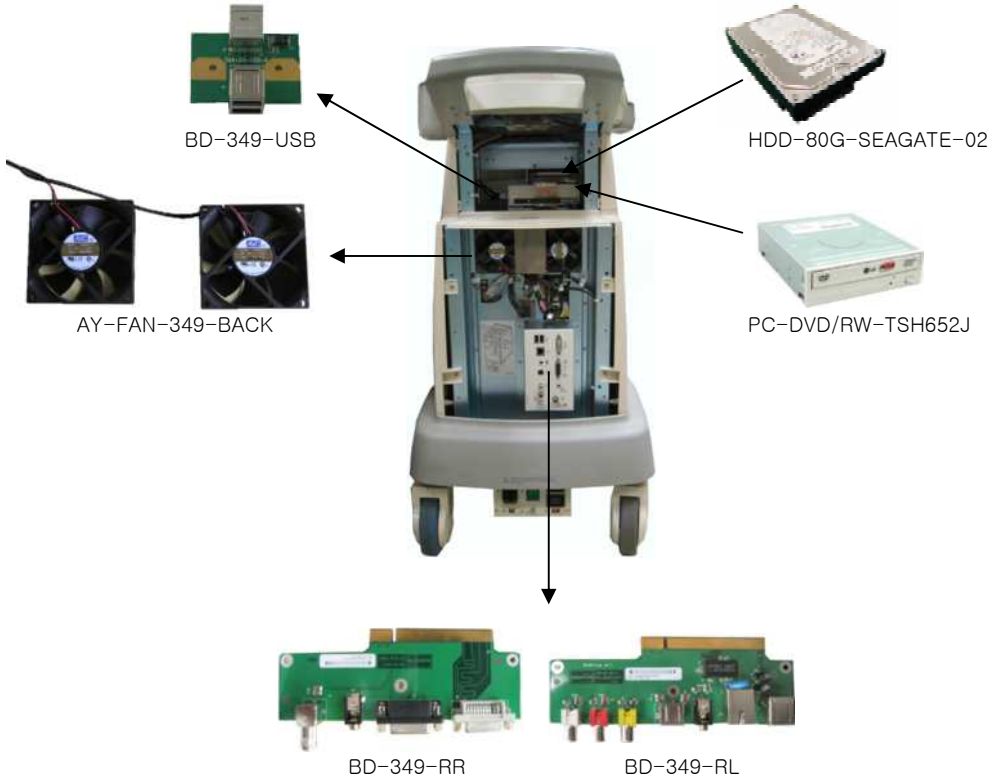

[Figure 11-4] Rear Plan

PART NUMBER	DESCRIPTION
BD-349-USB	USB BOARD SONOACE X6
AY-FAN-349-BACK	BACK FAN AY SONOACE X6
HDD-80G-SEAGATE-02	SEAGATE Barracuda 7200.9 80G
PC-DVD/RW-TSH652J	SUPER MULTI 20X PATA ODD
BD-349-RR	REAR PANEL RIGHT BD SONOACE X6
BD-349-RL	REAR PANEL LEFT BD SONOACE X6

[Table 11-3] PC Part

11.5 Power Part

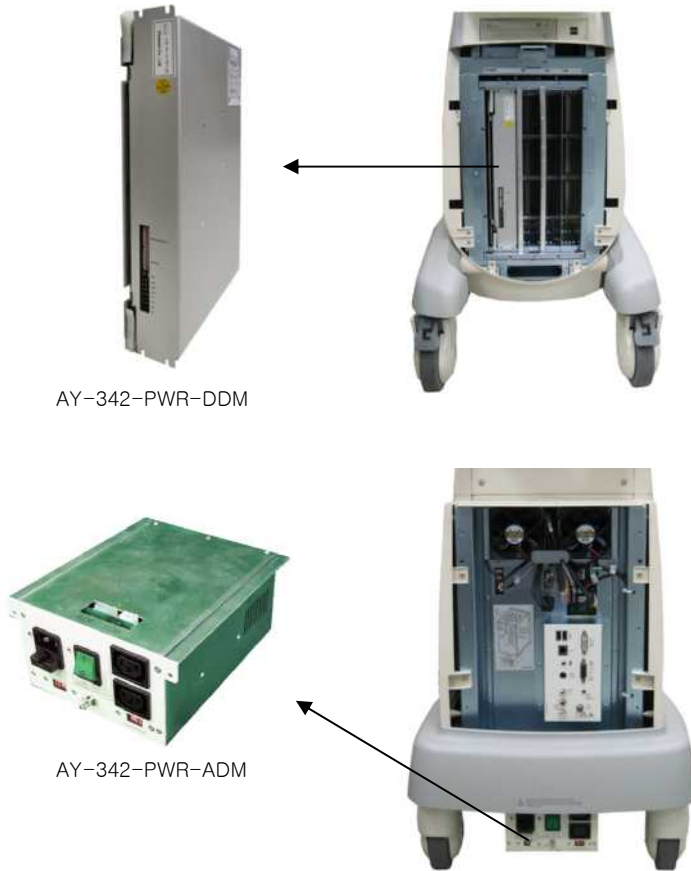

[Figure 11-5] Power Part

PART NAME	PART NUMBER	DESCRIPTION
DDM POWER	AY-342-PWR-DDM	POWER AY DC-DC MODULE SONOACE X4
ADM POWER	AY-342-PWR-ADM	POWER AY AC-DC MODULE SONOACE X4

[Table 11-4] Power Part

11.6 LCD Monitor

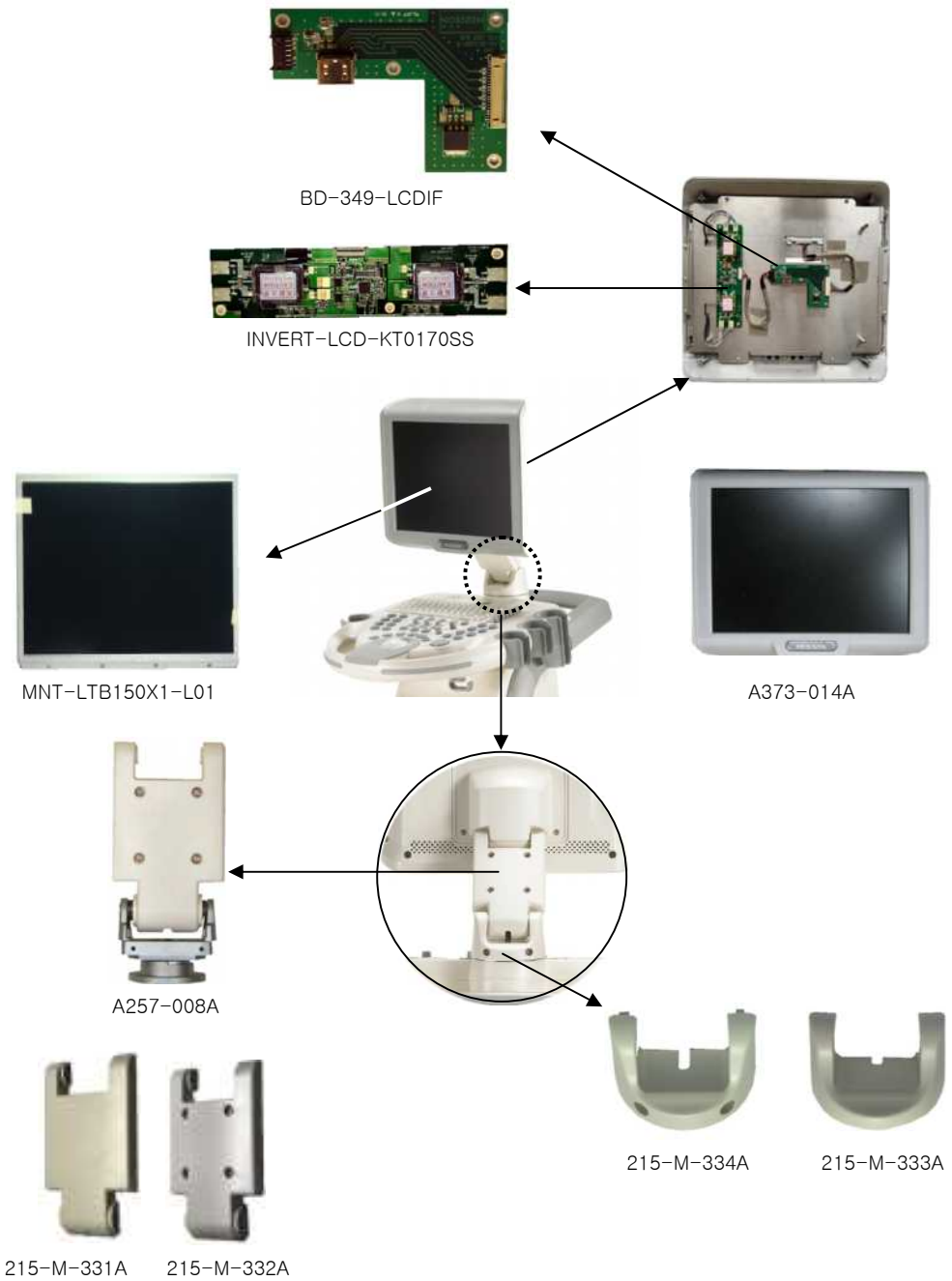

[Figure 11-6] LCD Monitor

PART NUMBER	DESCRIPTION
BD-349-LCDIF	LCD INTERFACE BOARD SONOACE X6
INVERT-LCD-KT0170SS	LCD INVERTER BD SONOACE X6
A373-014A	15" LCD MONITOR AY SONOACE X6
MNT-LTB150X1-L01	15" LCD PANEL SONOACE X6
A357-008A	HINGE AY SONOACE X6
215-M-331A	HINGE FRONT SONOACE X6
215-M-332A	HINGE REAR SONOACE X6
215-M-333A	SWIVEL FRONT SONOACE X6
215-M-334A	SWIVEL REAR SONOACE X6

[Table 11-5] LCD Monitor

11.7 Control Panel

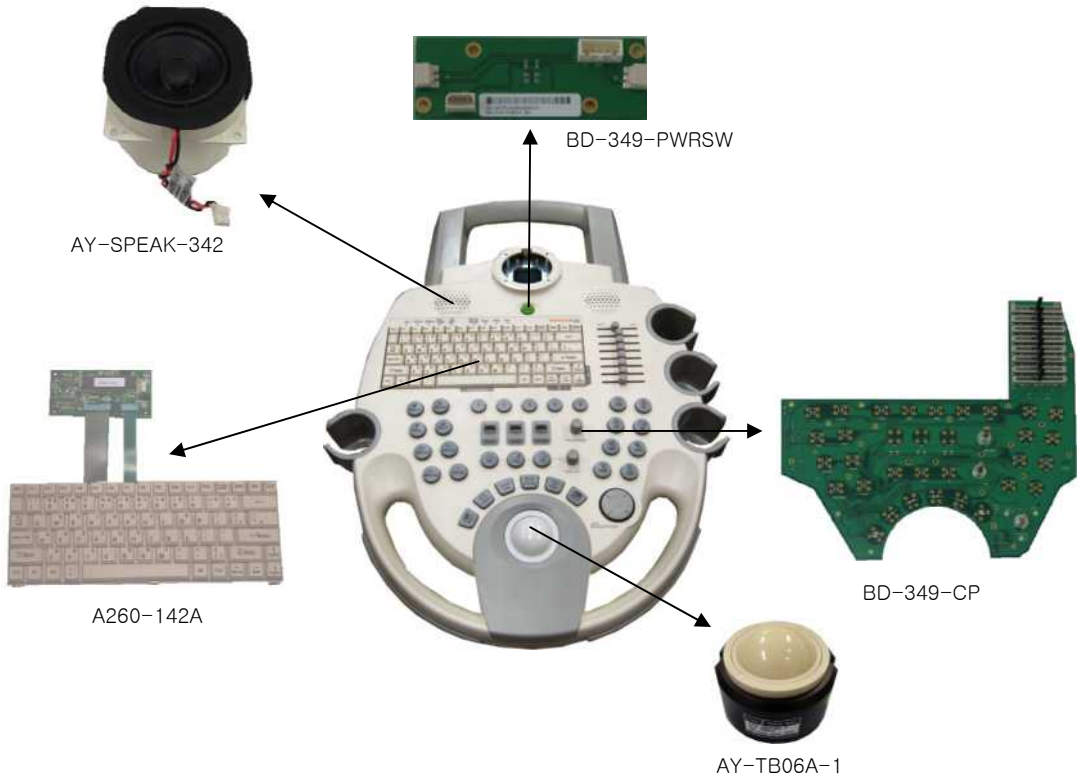

[Figure 11-7] Control Panel

PART NUMBER	DESCRIPTION
AY-SPEAK-342	SPEAK CABLE AY SONOACE X6
BD-349-PWRSW	POWER S/W BD SONOACE X6
A260-126A	KEY MATRIX BD ACCUVIX V20
A260-142A	ALPHA-NEUMERIC KBD AY SAX6
BD-349-CP	CONTROL PANEL BD SONOACE X6
AY-TB06A-1	TRACKBALL ORACOM T/B CIRCLE TYPE UNIT 58MM

[Table 11-6] Control Panel

11.8 Probe

PART NUMBER	DESCRIPTION
PB-C3-7EP	C3-7EP
PB-C4-9ED	C4-9ED
PB-HL5-12ED	HL5-12ED
PB-L5-12/50EP	L5-12/50EP
PB-NER4-9ES	NER4-9ES
PB-NEV4-9ES	NEV4-9ES
PB-P2-4AH	P2-4AH
PCW-20-FGG/3B	CW2.0
PCW-40-FGG/3B	CW4.0

[Table 11-7] Probe

SONOACE X6 Service Manual

Publisher Medison Co., Ltd

Address Discusser & Medison Bldg., 1003, Deachi-dong, Gangnam-gu,
Seoul 135-280 Korea

Homepage <http://www.medison.com>